

21 Clutch

| | Page |
|--|---------|
| Specifications | 21- 0/3 |
| 21 00 006 Bleeding Clutch Hydraulic System | 00/1 |
| 21 21 000 Removing and Installing Clutch | 21/1 |
| 21 51 000 Removing and Installing Clutch Release | 51/1 |
| 001 Replacing Clutch Release | 51/1 |
| 21 52 000 Removing and Installing Clutch Master Cylinder | 52/1 |
| 010 Removing and Installing Clutch Slave Cylinder | 52/2 |
| 502 Overhauling Clutch Master Cylinder | 52/2 |
| 512 Overhauling Clutch Slave Cylinder | 52/2 |
| Troubleshooting Clutch | 52/3 |

SPECIFICATIONS

Clutch

Model

320 i

Clutch

hydr.-operated single dry plate diaphragm spring clutch with torsion damper and automatic adjustment

Model

F & S MF 215 K Sph

Contact pressure

N/kp (lbs)

4000 ... 4700 / 407 ... 479 (897 ... 1056)

Identification marks

none

Max. clutch unbalance

gcm

15

Max. out-of-true at ends of diaphragm springs

mm (in.)

0.6 (0.024)

Drive Plate

F & S 215 PSD

Color code on hub

red

Outside drive plate diameter

mm (in.)

216 ± 1 (8.504 ± 0.039)

Inside drive plate diameter

mm (in.)

144 ± 1 (5.669 ± 0.039)

Type of clutch liner

215 D

Liner

engine side

Textar T 50/17

transmission side

Textar T 50/17

Liner thickness

mm (in.)

3.7 (0.146)

transmission side

3.7 (0.146)

Total thickness removed

mm (in.)

9.75 ... 10.55 (0.384 ... 0.415)

pressed with 489 kp/1078 lbs

mm (in.)

8.9 ± 0.25 (0.350 ± 0.010)

Min. thickness removed

mm (in.)

9.05 (0.356)

pressed with 489 kp/1078 lbs

mm (in.)

7.8 (0.307)

Max. drive plate runout at 210 mm/8.268" dia.

mm (in.)

0.6 (0.024)

Max. drive plate unbalance

gcm

10

Max. deviation from parallel between both

liner face surfaces

0.15 (0.006)

Release Bearing

| | | |
|---------|---------------|----------|
| Release | Inside dia. A | mm (in.) |
| | Height B | mm (in.) |
| | Height C | mm (in.) |

self-centering axial ball bearing
 $38 \begin{matrix} + 0.112 \\ + 0.050 \end{matrix} (1.496 \begin{matrix} + 0.004 \\ + 0.002 \end{matrix})$
 $52.5 \pm 0.4 (2.067 \pm 0.016)$
 $25.5 \pm 0.25 (1.004 \pm 0.010)$

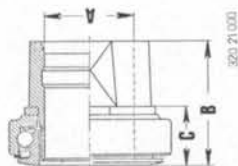

inboard, pressed sheet metal part mounted on pivot pin
 automatic adjustment

| | | |
|------------------------------|--|-------------------|
| Release lever | | |
| Clutch play at release lever | | approx. 5 (0.197) |
| Play at clutch pedal | | 155 (6.102) |
| Clutch pedal travel | | |

Master Cylinder

| | | |
|---------------|--|-----------------------|
| Bore diameter | | Teves or Kugelfischer |
| Stroke | | 19.05 (0.750) |
| | | 32.00 (1.260) |

Slave Cylinder

| | | |
|---------------|--|-----------------------|
| Bore diameter | | Teves or Kugelfischer |
| Stroke | | 20.64 (0.812) |
| | | 23.00 (0.905) |

Torque Specifications in Nm / kpm (ft. lbs.)

| | | | |
|--|-------------------------------------|------------------------------------|---|
| Clutch to flywheel | 22 ... 24 / 2.2 ... 2.4 (16 ... 17) | Slave cylinder mounting screws | 25 ... 28 / 2.5 ... 2.8 (18 ... 20) |
| Pressure rod to clutch pedal | 32 ... 36 / 3.2 ... 3.6 (23 ... 26) | Clutch and brake pedal pivot bolt | 25 ... 28 / 2.5 ... 2.8 (18 ... 20) |
| Clutch line collar screws (master and slave cylinders) | 13 ... 16 / 1.3 ... 1.6 (10 ... 12) | Clutch/transmission case to engine | M 10 47 ... 51 / 4.7 ... 5.1 (34 ... 37) |
| Master cylinder mounting screws | 22 ... 24 / 2.2 ... 2.4 (16 ... 17) | Guard to case M 6 mtg. screws | M 8 25 ... 27 / 2.5 ... 2.7 (18 ... 19.5) |
| | | | 8 ... 10 / 0.8 ... 1.0 (6 ... 7) |

21 00 006 BLEEDING CLUTCH HYDRAULIC SYSTEM

Determining release stroke:

Guide gauge 21 2 060 into opening provided and push it in until it rests against piston rod.

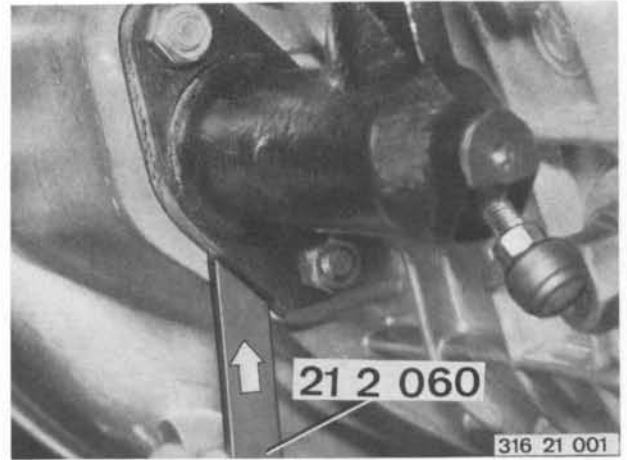

Depress clutch pedal. Detach slave cylinder and measure line (M) marked by gauge. If release stroke (marked line) is less than 20 mm (0.787 in.), there could either be air in hydraulic system or a sleeve may be defective.

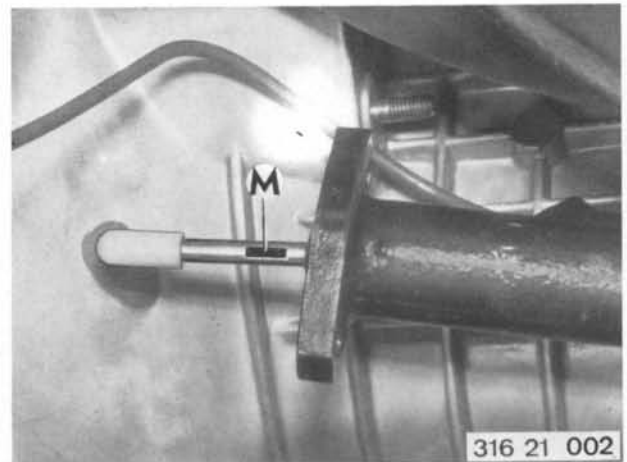

A) With Bleeder

Unscrew threaded connection on fluid tank.
Connect bleeder.

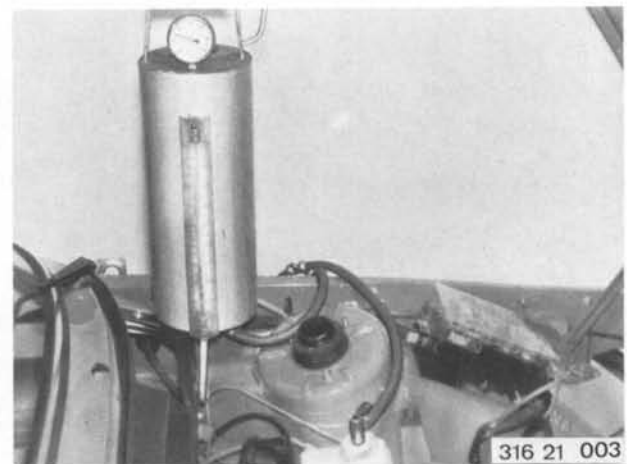

Unscrew bleeder screw on clutch slave cylinder until no more air bubbles escape.
Depress clutch pedal several times as long as screw is loosened.

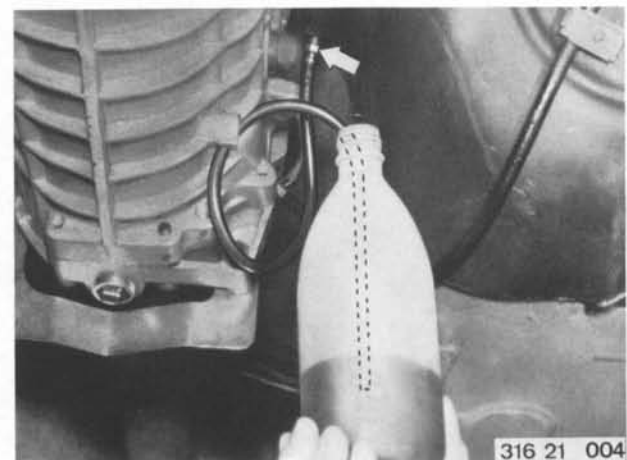

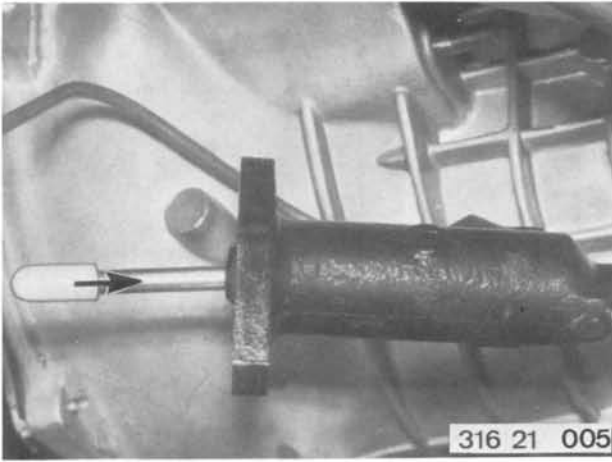

Take slave cylinder off of transmission.
 Press in piston rod up to stop in slave cylinder
 and let it return slowly.
 This will press any remaining air back into the fluid
 tank and the max. release travel will be reached.
Never depress clutch pedal as long as slave cylinder
 is removed.

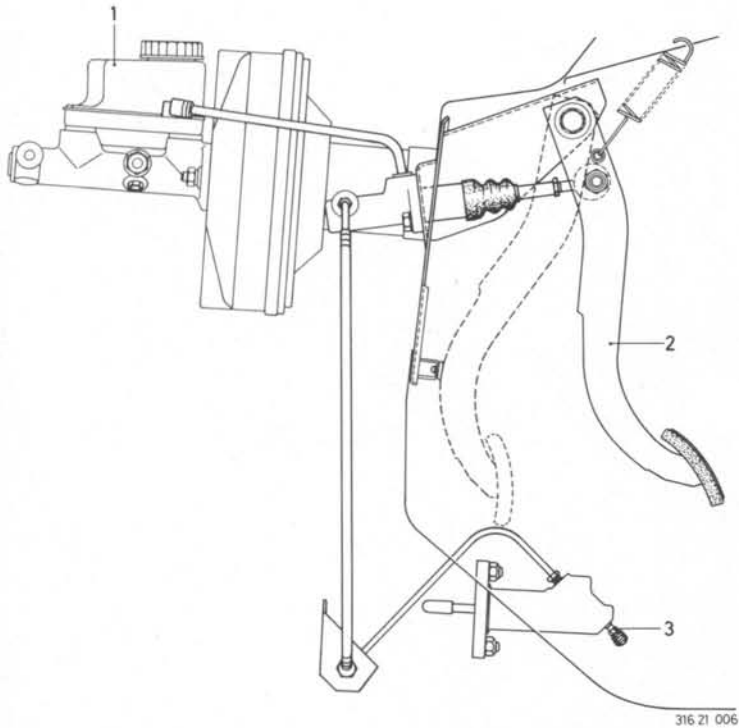

B) Without Bleeder

Fill tank (1).
 Connect bleeder hose to bleeder screw (3).
 End of bleeder hose must be in a container filled
 with brake fluid, so that air cannot be drawn in
 during bleeding procedures.
 Depress clutch pedal (2) all the way to stop about
 10 times and then hold it down.
 Unscrew bleeder screw (3). Tighten bleeder screw (3)
 again when no more air bubbles escape.
 Release clutch pedal and depress it another 10 times.
 Repeat this procedure until no more air bubbles es-
 cape from hydraulic system.

Caution! Tank (1) must be kept full with fluid.

21 21 000 REMOVING AND INSTALLING CLUTCH

Check clutch for wear before removing. Clutch liners are good, if gauge 21 2 060 can be slid into opening of slave cylinder up to stop on grip.



If gap between gauge grip and slave cylinder is more than about 5 mm (0.197 in.), clutch is worn and must be replaced.

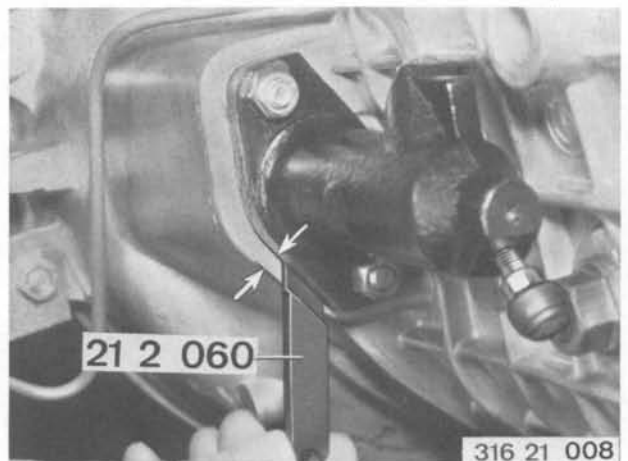

Remove transmission - 23 00 020.
Check out-of-true at end of diaphragm springs ¹⁾.
Block flywheel with holder 11 2 160.
Loosen mounting bolts one after the other by 1 to 1 1/2 turns until clutch is without tension.
Remove mounting bolts, clutch and drive plate.

Caution! Don't throw or drop clutch. Improper handling could cause the tangential leaf springs holding clutch in axial direction to be bent off. The diaphragm springs would provide the stroke, but because of the lame leaf springs the pressure ring cannot lift high enough to release the drive plate.

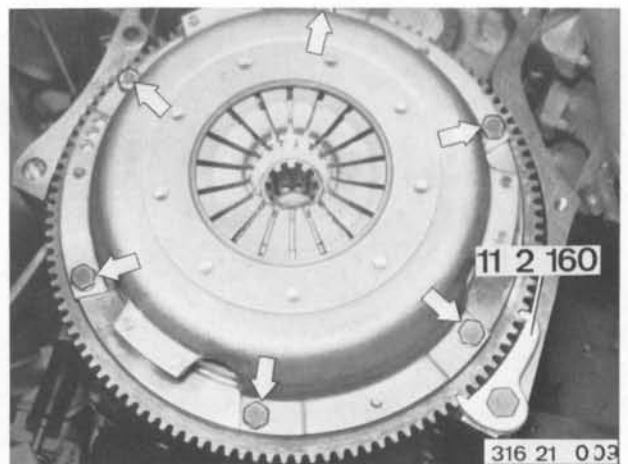

Check drive plate for wear (A), cracks and torsional damper for tightness of spring elements.

Installation Note! Note correct side of clutch.

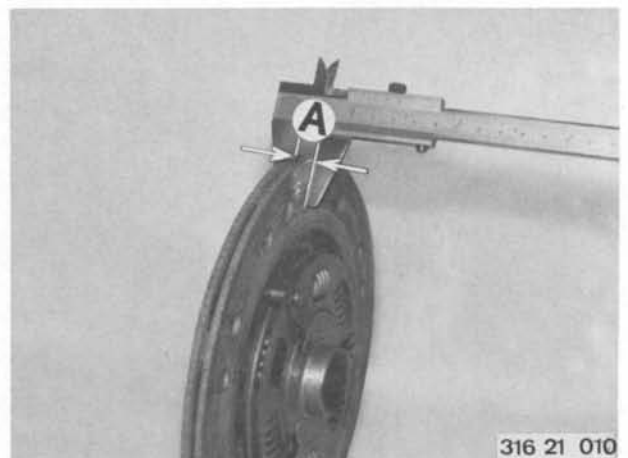

1) See Specifications

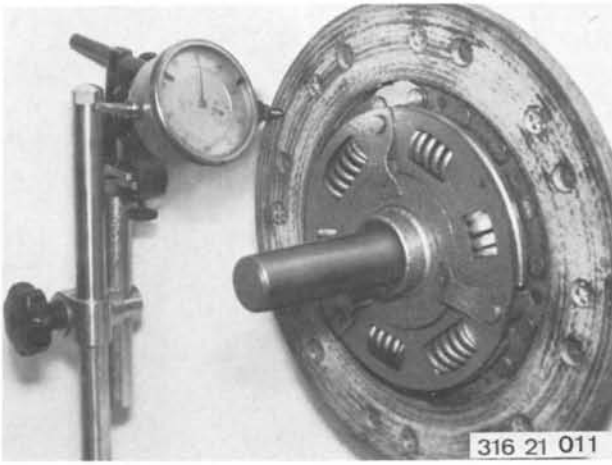

Check drive plate with liner for lateral runout¹⁾.

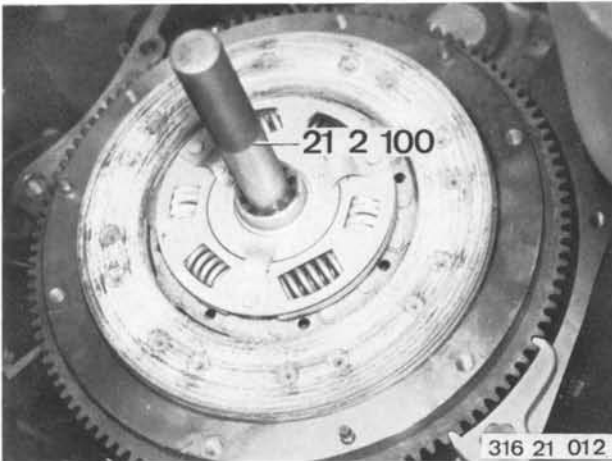

Installation Note! Check movement of needle bearing in crankshaft and replace it if necessary.
Check flywheel for cracks.
Center drive plate in flywheel with Special Tool 21 2 100.

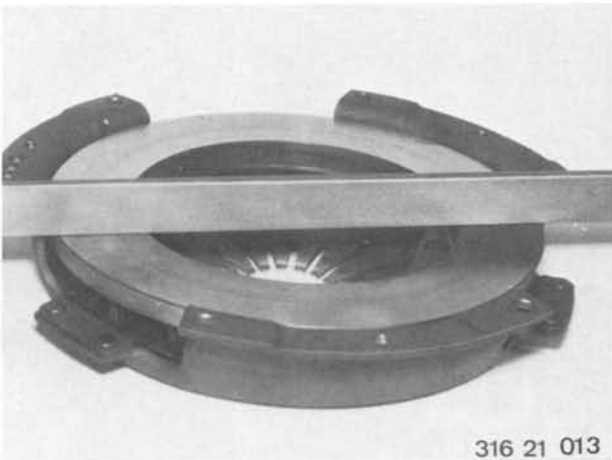

Inspect clutch for cracks, wear and burnt spots visually.
Pressure surface must be level.



Check rivets for wear and tightness visually.
Replace a clutch with loose or worn rivet heads.

1) See Specifications

Place clutch over dowel pins.
Tighten mounting bolts evenly one after the other to specified torque. 1)

Installation Note! Apply light coat of Molykote Longterm 2 to splines of transmission input shaft.

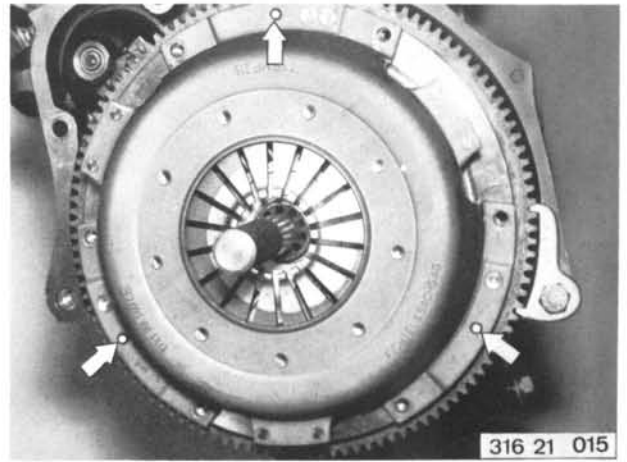

316 21 015

Clutch Assembly

- 1 Crankshaft
- 2 Needle bearing
- 3 Flywheel
- 4 Drive plate
BMW 320 i F & S 215 PSD
- 5 Pressure plate
BMW 320 i F & S MF 215 K
- 6 Release
BMW 320 i F & S C = 25.5 ± 0.25 mm ($1.004 \pm .010$ ")
- 7 Release lever
- 8 Slave cylinder

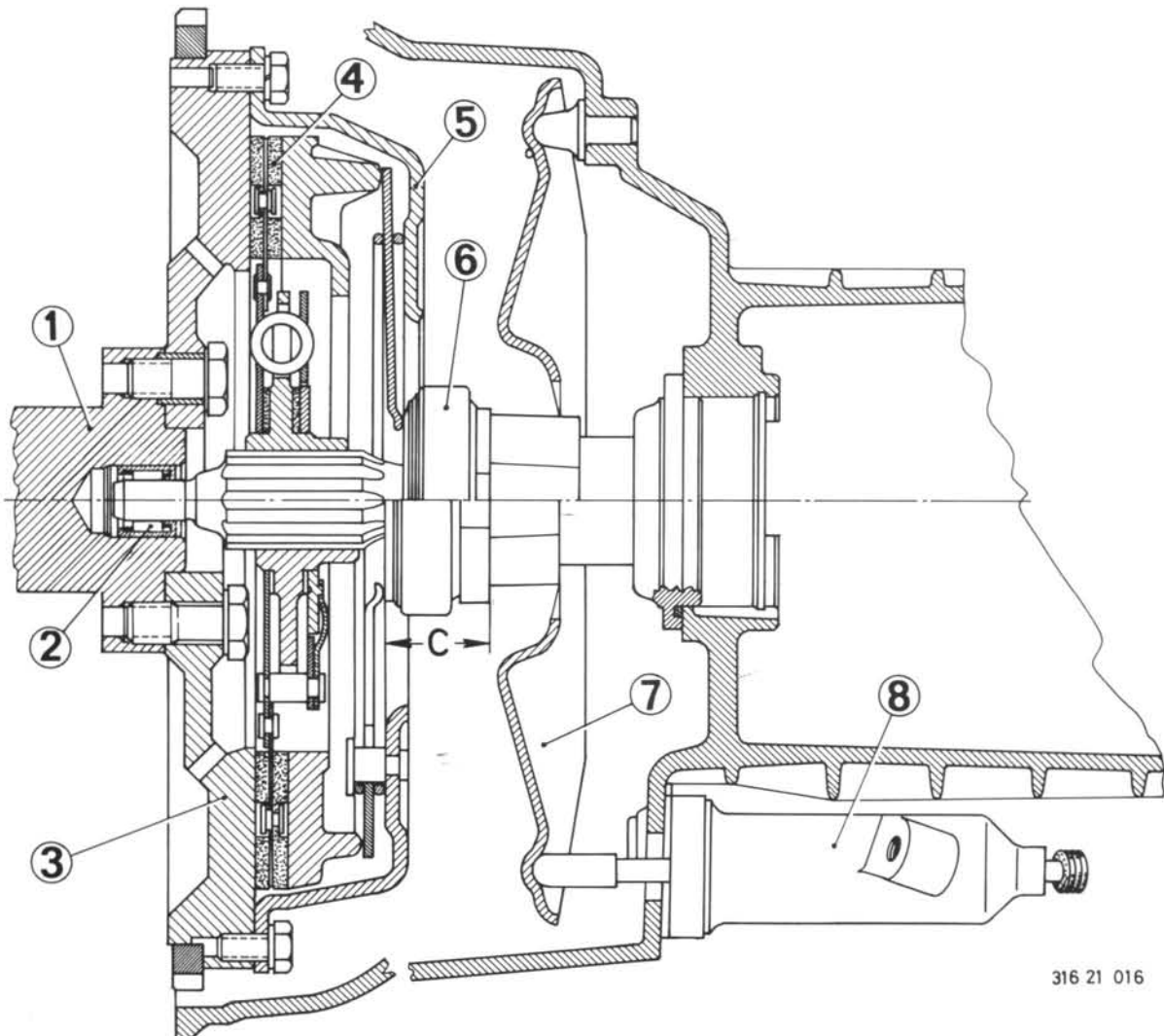

316 21 016

1) See Specifications

21 51 000 REMOVING AND INSTALLING CLUTCH RELEASE

Remove transmission - 23 00 020.
Remove spring (1) and release lever (2) with release (3).

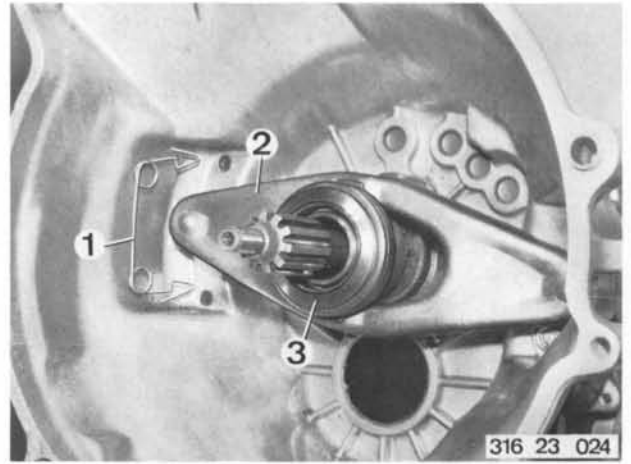

Installation Note! Fill lubrication groove (N) with Molykote BR 2 - 750. Apply light coat of DC 44 grease to guides (F) and bearings (L). Nonconformance could cause bearing to seize on guide sleeve.

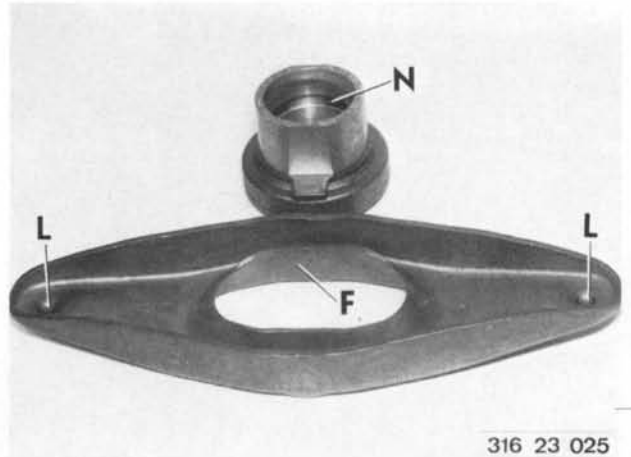

21 51 001 REPLACING CLUTCH RELEASE

Remove clutch release - 21 51 000.
Note specified height of release B and C¹⁾.
BMW 320 i F & S No. 3151 035 001
Fill lubrication groove with Molykote BR 2-750.

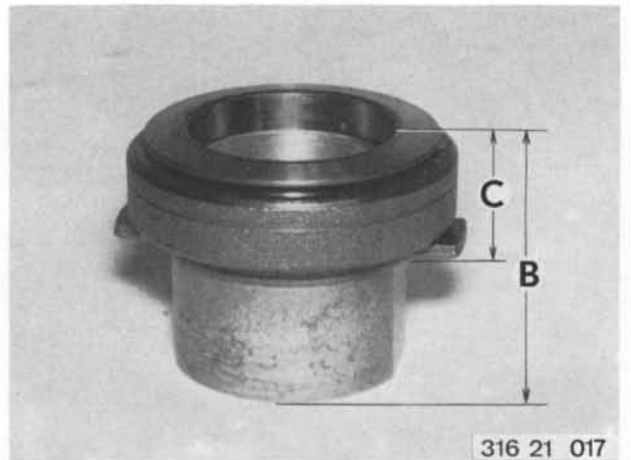

1) See Specifications

21 52 000 REMOVING AND INSTALLING CLUTCH MASTER
CYLINDER

Detach lower left instrument panel trim.
Detach accelerator cable and pull it forward out of
engine fire wall.
Detach piston rod (1) at clutch pedal.

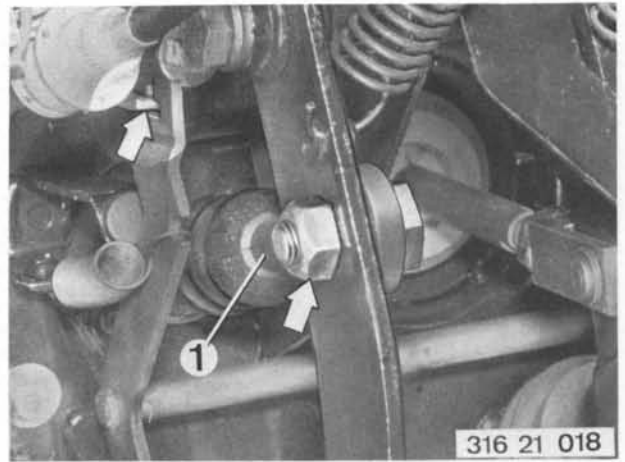

Loosen nut (2) and unscrew piston rod (1).
Installation Note! Adjust pedal travel¹⁾ with piston
rod (1).

Caution! Note bushings (3).
Coat bushings and shaft with Molykote Longterm 2.

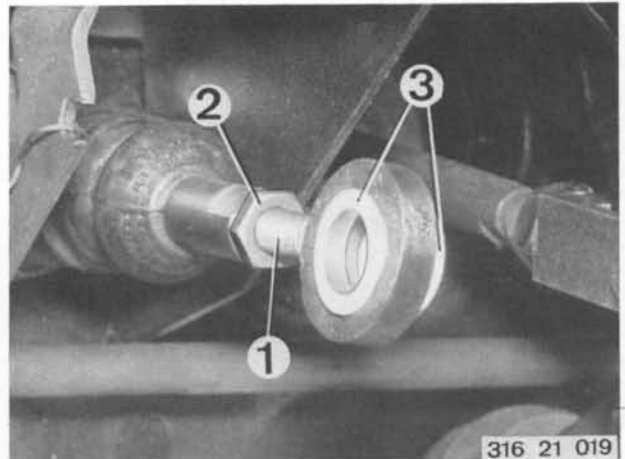

Draw off brake fluid from tank until level drops
below refill line connection.

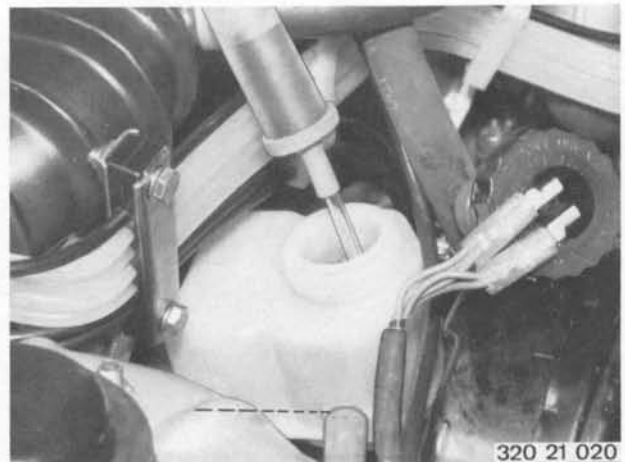

Pull out refill line.
Detach line (3) to slave cylinder.
Detach master cylinder at engine fire wall and re-
move forward.

Installation Note! Bleed clutch - 21 00 006.

Caution! Install clutch hose running from master to
slave cylinder as close as possible to engine fire
wall and wheelhouse, but not too tight. Secure line
(3) in this position.

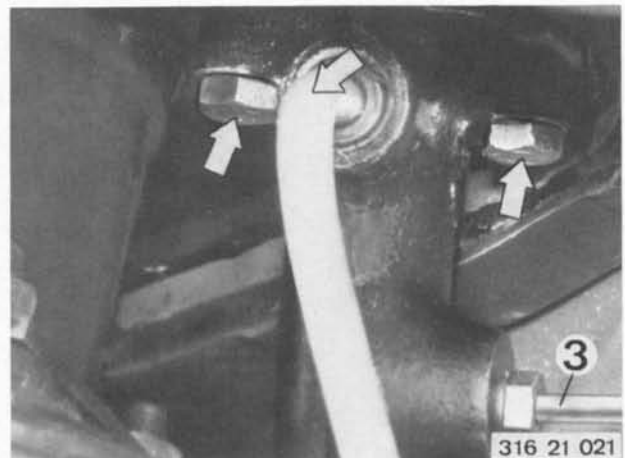

1) See Specifications

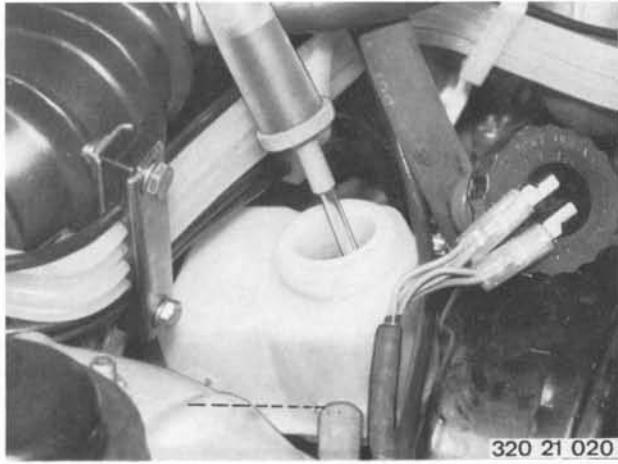

320 21 020

21 52 010 REMOVING AND INSTALLING CLUTCH SLAVE CYLINDER

Draw off brake fluid from tank until level drops below refill line connection.

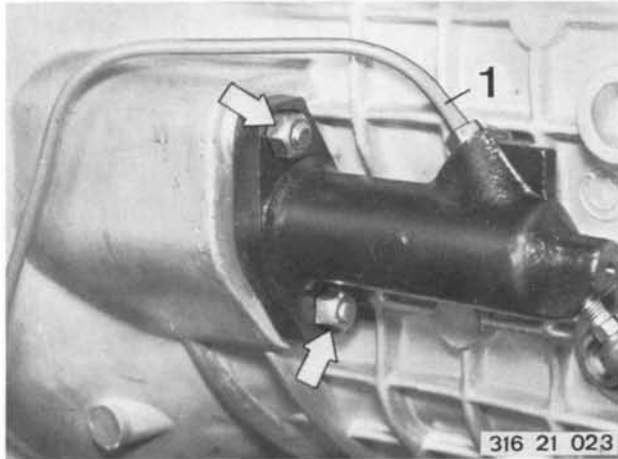

316 21 023

Take slave cylinder off of transmission.
Remove slave cylinder.
Detach line (1).

Installation Note! Bleeder screw faces down.
Install front pressure rod with Molykote Longterm 2.
Bleed clutch hydraulic system - 21 00 006.

21 52 502 OVERHAULING CLUTCH MASTER CYLINDER

- Removed -

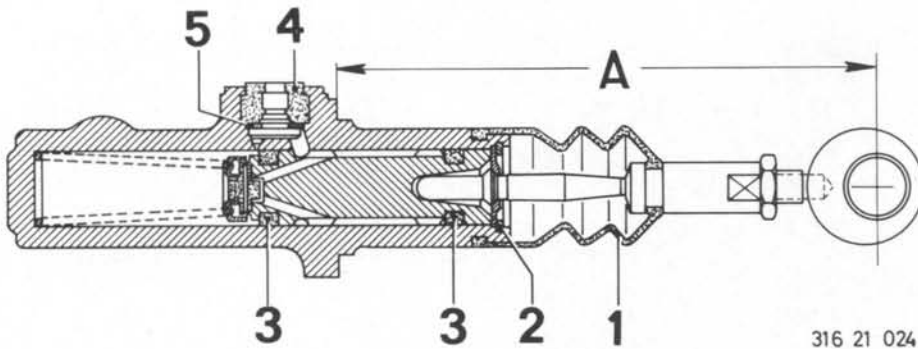

316 21 024

Disassemble master cylinder.
Clean cylinder bore and parts with gasoline.

If cylinder bore is scored or corroded, replace master cylinder assembly.

Install repair kit consisting of:

- 1 Dust cap
- 2 Circlip
- 3 Grooved rings
- 4 Sealing plug
- 5 Plain washer

A = 140 ± 0.5 mm (5.512 \pm .020")

21 52 512 OVERHAULING CLUTCH SLAVE CYLINDER

- Removed -

Disassemble slave cylinder.
Clean cylinder bore and parts with gasoline.

If cylinder bore is scored or corroded, replace slave cylinder assembly.

Install repair kit consisting of:

- 1 Notched ring
- 2 Dust cap
- 3 Grooved sleeve

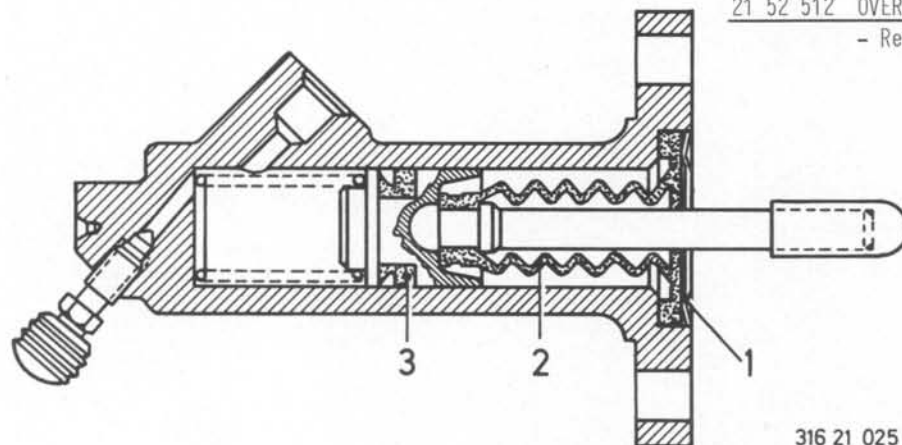

316 21 025

Troubleshooting Clutch

| Condition | Cause | Correction |
|---------------------------|---|--|
| Clutch slips | <ul style="list-style-type: none"> a) Clutch contact pressure¹⁾ too low b) Clutch liners¹⁾ seriously worn c) Oil on liners; transmission or crankshaft seal defective d) Clutch runs hot e) Clutch not genuine BMW part | <ul style="list-style-type: none"> a) Replace clutch b) Replace drive plate c) Replace radial oil seal, gasket and drive plate d) Replace clutch e) Install genuine BMW clutch |
| Clutch grabs | <ul style="list-style-type: none"> a) Liners¹⁾ not as specified b) Oil on liners c) Release pressure on one side d) Pressure plate pressure uneven e) Crankshaft not aligned with transmission input shaft f) Engine and transmission mounts defective g) Drive plate not genuine BMW part | <ul style="list-style-type: none"> a) Replace drive plate b) Replace drive plate c) Check release lever d) Replace pressure plate e) Check centering surfaces of engine and transmission f) Replace engine and transmission mounts g) Install genuine BMW drive plt. |
| Clutch will not disengage | <ul style="list-style-type: none"> a) Drive plate out of alignment or liners broken b) Drive plate runout¹⁾ excessive c) Liner rusted to flywheel d) Drive plate stuck on transmission input shaft e) Needle bearing in crankshaft for transmission input shaft shot f) Air in clutch hydraulic system | <ul style="list-style-type: none"> a) Replace drive plate b) Align or replace drive plate c) Clean flywheel, roughen surface of liners with emery cloth d) Service drive plate on transmission input shaft, replace damaged parts as required e) Replace needle bearing in crankshaft f) Bleed clutch hydraulic system |
| Clutch noise | <ul style="list-style-type: none"> a) Unbalance¹⁾ of clutch and drive plate excessive b) Torsional damper defective c) Clutch release defective d) Needle bearing in crankshaft for transmission input shaft e) Clutch rivets loose | <ul style="list-style-type: none"> a) Replace clutch and drive plate b) Replace drive plate c) Replace clutch release d) Replace needle bearing in crankshaft e) Replace clutch |

1) See Specifications