

23 Manual Transmission

	Page
Specifications	23- 0/3
23 00 020 Removing and Installing Transmission	00/1
23 11 000 Removing and Installing/Sealing Transmission Case	11/1
101 Replacing Backup Light Switch	11/3
590 Removing and Installing Clutch Release Guide Sleeve	11/3
591 Replacing Clutch Release Guide Sleeve	11/4
23 12 051 Replacing Output Flange Radial Oil Seal	12/1
081 Replacing Selector Shaft Radial Oil Seal	12/2
131 Replacing Speedometer Pinion Sleeve Cord Seal	12/2
521 Replacing Input Shaft Radial Oil Seal	12/2
23 21 500 Removing and Installing Input and Output Shafts	21/1
551 Replacing Output Shaft	21/9
701 Replacing All Grooved Ball Bearings	21/11
23 22 100 Removing and Installing Speedometer Pinion	22/1
551 Replacing 3rd and 4th Speed Gear Sets	22/1
651 Replacing Reverse Gear Bushing	22/2
23 23 503 Replacing Synchronizing Rings	23/1
23 31 501 Replacing 1st/2nd and 3rd/4th Speed Selector Forks	31/1
721 Replacing All Sliding Blocks	31/1
751 Replacing Reverse Gear Selector Fork	31/1

SPECIFICATIONS

Manual Transmission

6.76

320 i

Manual Transmission

Getrag 242/9

12 mm (0.472") dia. dot of yellow paint at bottom rear left on transmission case cover
 four speed manual transmission with Borg Warner synchronization; 1 reverse gear
 floorshift

$$\frac{3.764}{\frac{31 \cdot 34}{20 \cdot 14}}$$

$$2.022$$

$$\frac{31 \cdot 30}{20 \cdot 23}$$

$$1.320$$

$$\frac{31 \cdot 23}{20 \cdot 27}$$

$$1.000$$

$$4.096$$

$$\frac{31 \cdot 17 \cdot 37}{20 \cdot 14 \cdot 17}$$

$$2.500$$

$$\frac{10}{4}$$

Replace if gap between synchronizing ring and clutch body is less than 0.8 mm (0.031 in.).
 Distance between new synchronizing ring and clutch body is 1.0 mm (0.039 in.)

$$5 \begin{matrix} - & 0.030 & - & 0.001 \\ - & 0.078 & - & 0.003 \end{matrix}$$

$$6 \begin{matrix} - & 0.070 & - & 0.002 \\ - & 0.145 & - & 0.005 \end{matrix}$$

Ratio
 No. of teeth

Ratio
 No. of teeth

Ratio
 No. of teeth

Ratio
 Ratio

No. of teeth

Ratio
 No. of teeth

Synchronizing ring wear limit mm (in.)

Selector fork guide web width, 1st ... 4th mm (in.)

Reverse gear mm (in.)

320 i

Model

Input/output shaft axial play	mm (in.)	0.5 ... 1.0 (0.020 ... 0.040)
Output shaft bearings		6306 C 3 FAG optionally SKF
Input shaft bearings		optional: FAG 6206 E. TNH. C 3 SKF 6206 C 3/361 781
Layshaft bearings	front	optional: FAG 6304 TNH C 3 SKF 6304 C 3/361 153 A
	rear	optional: FAG 6304 TNH C 3 SKF 6304 C 3/361 153 A
Layshaft bearing axial play	mm (in.)	0.1 ... 0.2 (0.004 ... 0.008)
Gear engaging surface		
Layshaft	3rd gear	0.074 ... 0.106 (0.003 ... 0.004)
	constant	0.086 ... 0.118 (0.003 ... 0.004)
Gear wheel removal pressure	kp (lbs.)	approx. 10,000 (22,000)
Gear wheel install pressure	kp (lbs.)	approx. 4,000 (8,800)
Gear wheel install temperature	° C (° F)	120 ... 150 (250 ... 300)

brand-name SAE 80 ... SAE 90 gear lube, not hypoid oil, or brand-name heavy duty single and multi-grade engine oils for internal combustion engines corresponding with engine oil specifications

Oil capacity	ltr (pts)	1.0 (2)
Weight (without oil)	kp (lbs.)	22.5 (50)

Torque Specifications in Nm / kpm (ft. lbs.)

Transmission to engine	M 8	25 ... 27 / 2.5 ... 2.7 (18 ... 19)	Transmission case cover	25 / 2.5 (18)
	M 10	47 ... 51 / 4.7 ... 5.1 (34 ... 37)	Selector arm to base	25 ... 28 / 2.5 ... 2.8 (18 ... 20)
Rubber mount/cross member		43 ... 48 / 4.3 ... 4.8 (31 ... 35)	Oil drain plug	40 ... 60 / 4.0 ... 6.0 (29 ... 43)
Output flange		100 / 10.0 (72)	Base to transmission	20 ... 25 / 2.0 ... 2.5 (15 ... 18)
Support ring		10 / 1.0 (7)	Guide sleeve	10 / 1.0 (7)

Cross Section Drawing of Standard Transmission 242/9

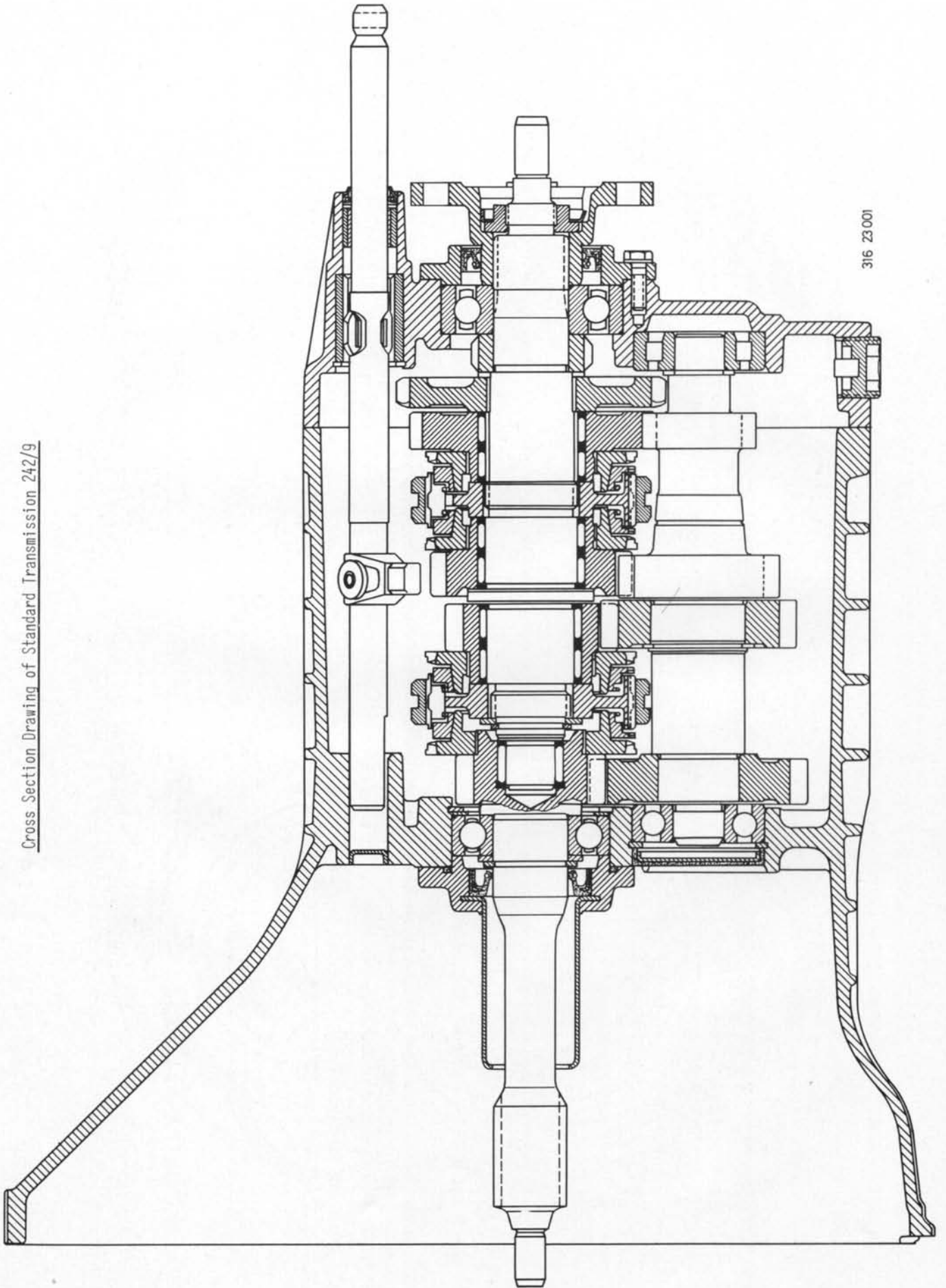

316 23001

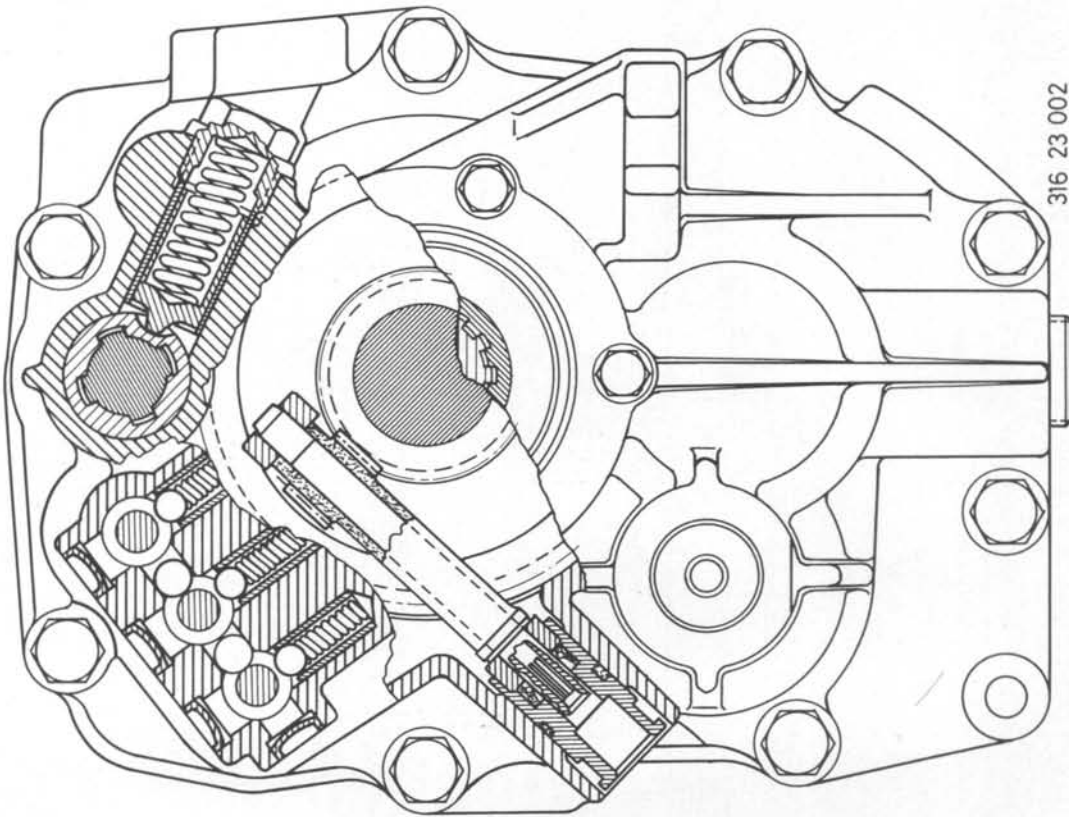

316 23 002

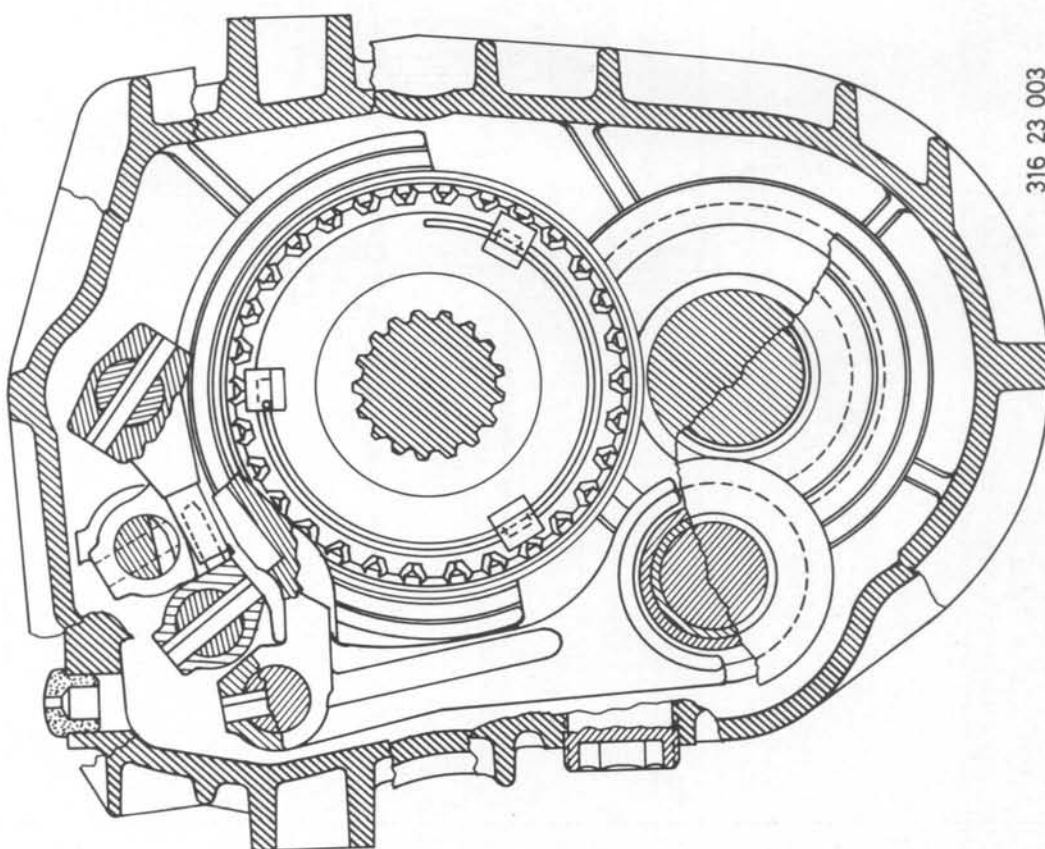

316 23 003

23 00 020 REMOVING AND INSTALLING TRANSMISSION

Unscrew all transmission mounting bolts accessible from above.
Swing up bracket (H) and also secure it when installing.

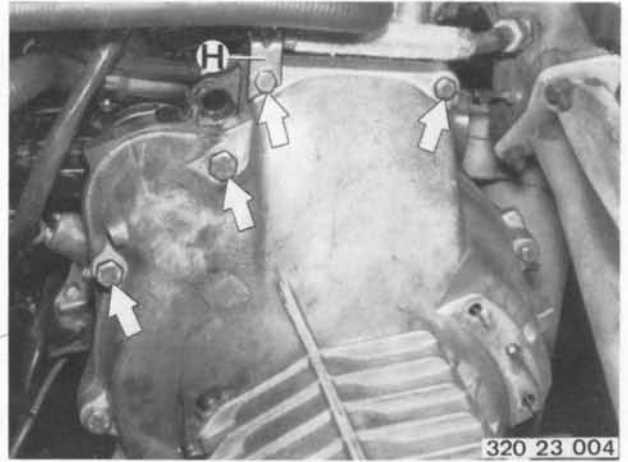

Remove exhaust support.

Installation Note!

Bolt exhaust pipe to exhaust manifold.
Loosen holder (1).
Press support (2) against exhaust pipe to remove tension and secure.
Any other sequence of installation could result in loud drumming noise.

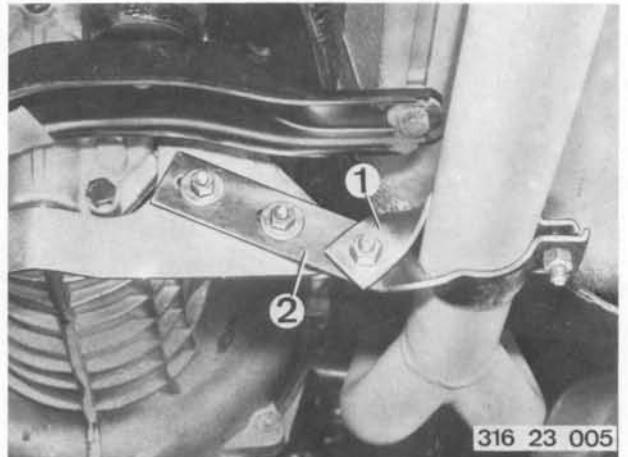

Detach exhaust pipe at exhaust manifold.

Installation Note! Check gasket and replace, if necessary.

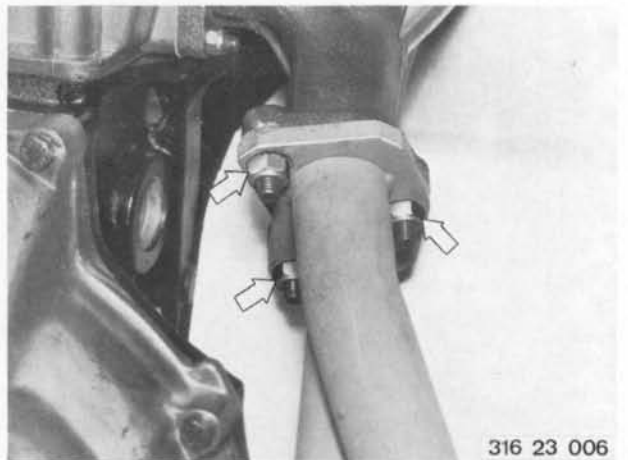

Detach propeller shaft at transmission.
Guibo coupling remains on propeller shaft.

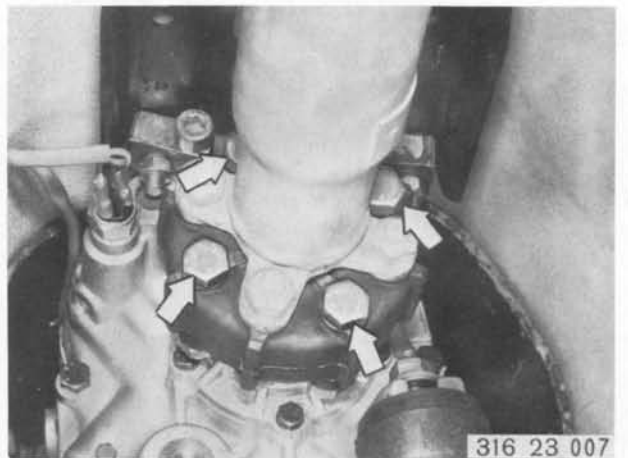

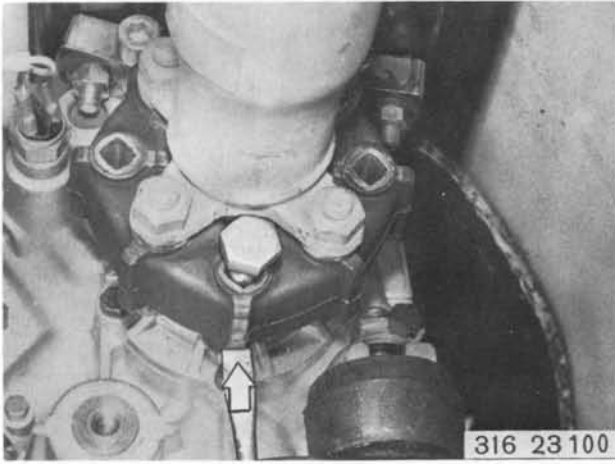

Installation Note! Don't damage bolt threads.
Press up Guibo coupling accordingly.
Only use stop nuts once.

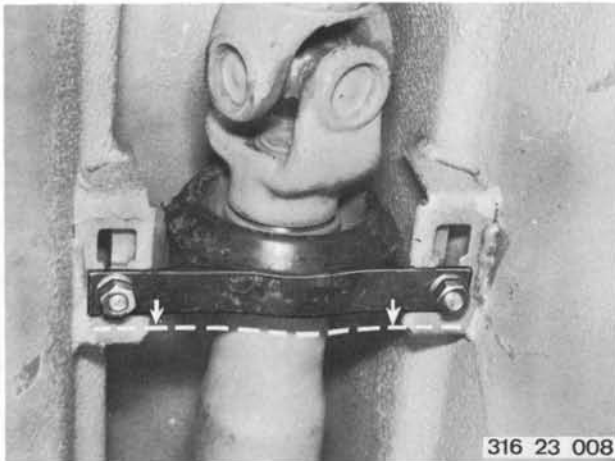

Detach heat guard.
Detach center bearing.
Bend down propeller shaft and pull it off of centering journal.

Installation Note! Preload center bearing by 2 mm (0.078 in.) in forward direction.

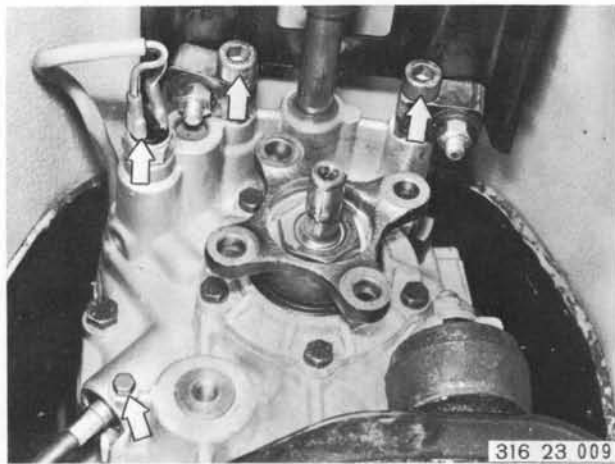

Remove speedometer shaft.
Disconnect wire at backup light switch.
Take harness out of holders on transmission.
Take console off of transmission.

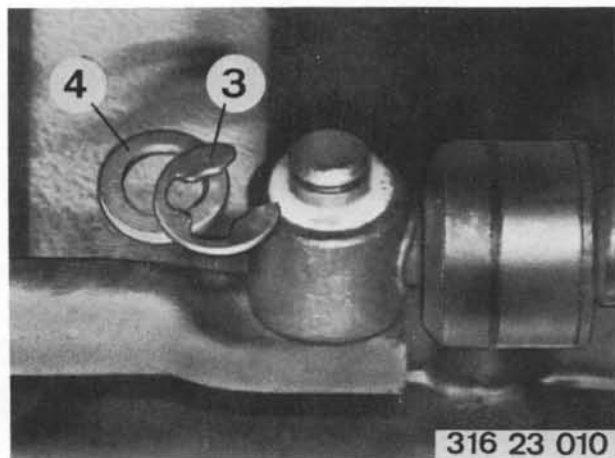

Lift off circlip (3) and remove washer (4).
Pull out selector rod.

Detach clutch slave cylinder.

Installation Note! Note location. Bleeder screw faces down. Loosen holder (5).

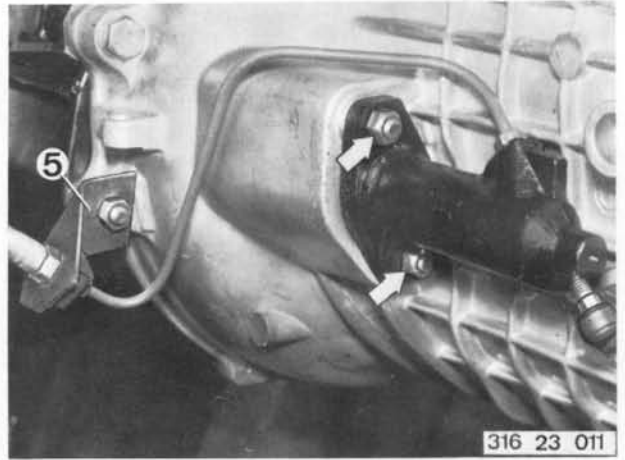

Remove cover.

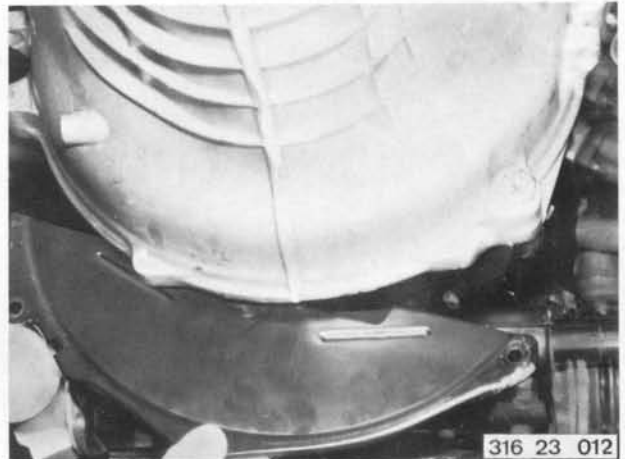

Detach cross member at body.

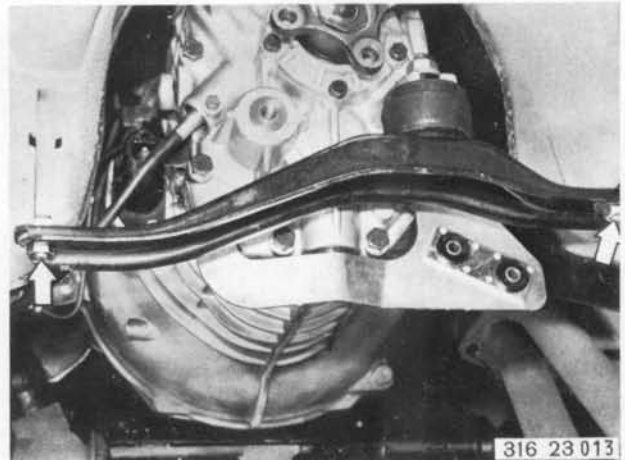

Unscrew rest of transmission mounting bolts.
Pull out transmission toward rear.

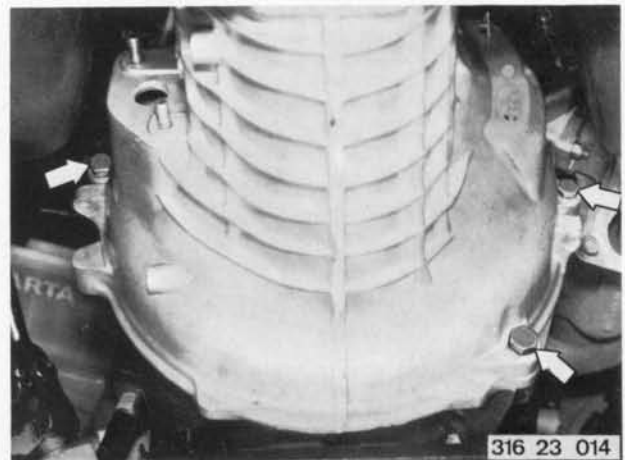

23 11 000 REMOVING AND INSTALLING/SEALING TRANSMISSION CASE

Remove transmission - 23 00 020.
Detach cross member and exhaust support holder.

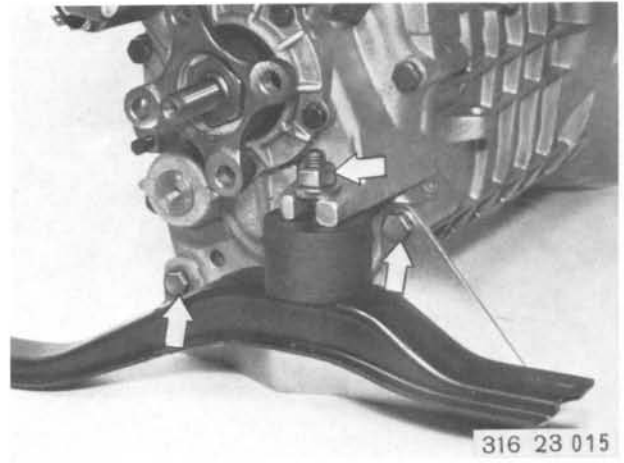

Secure transmission to Special Tool 23 0 050 and Special Tool 00 1 500.
Drain oil.

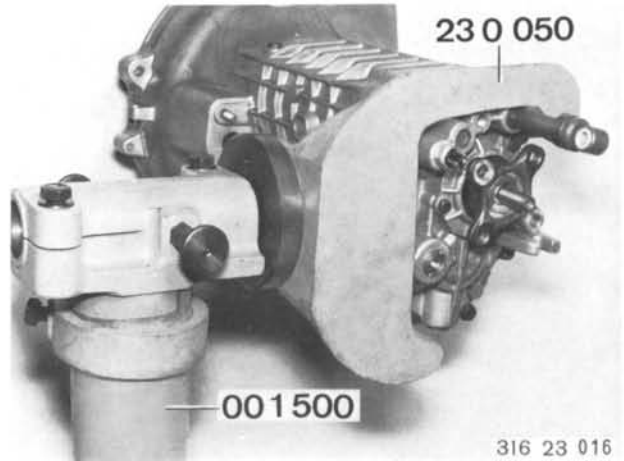

Remove guide sleeve - 23 11 590.
Remove circlip (1).
Remove shims (2).

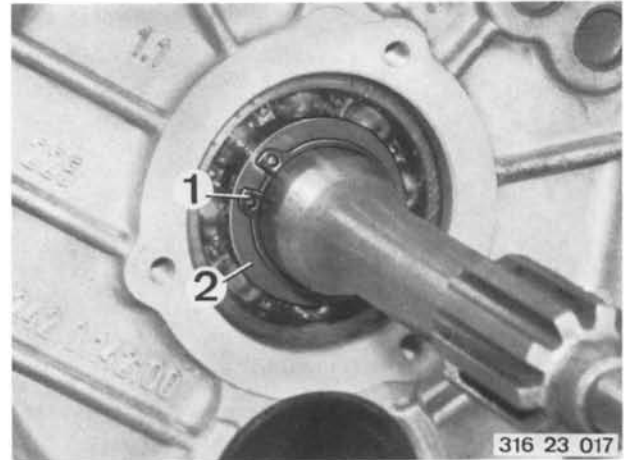

Unscrew transmission case cover mounting bolts.
Drive dowel pins (3 and 4) out of transmission case cover.

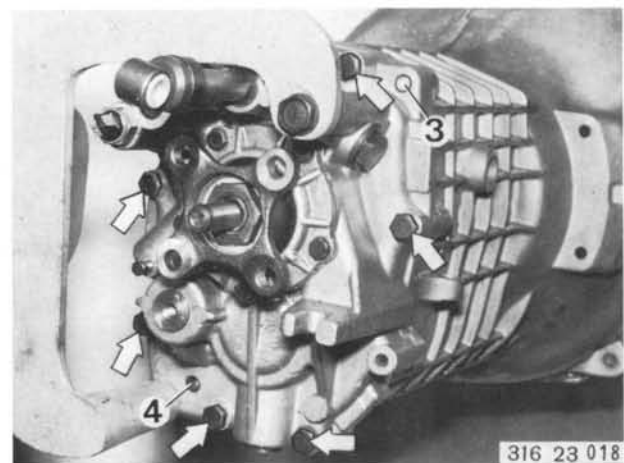

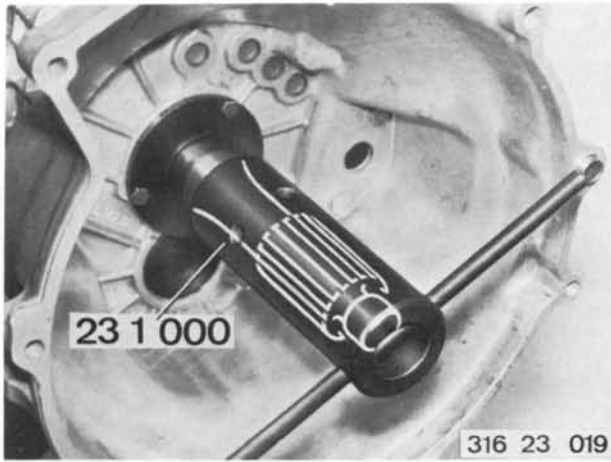

Make up pressure pad of brass or steel, 28 mm (1.102") x 25 mm (0.984") long.
Place pressure pad on input shaft.
Mount Special Tool 23 1 000 on case.
Don't use both pressure pins.

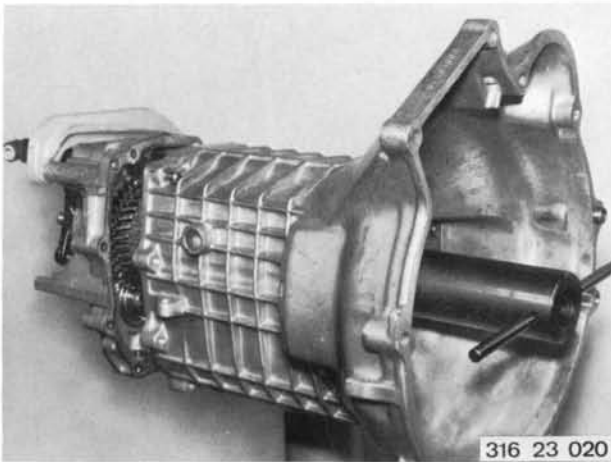

Press off transmission case.

Caution! Shims on input shaft and layshaft.

Installation Note! Replace gasket.

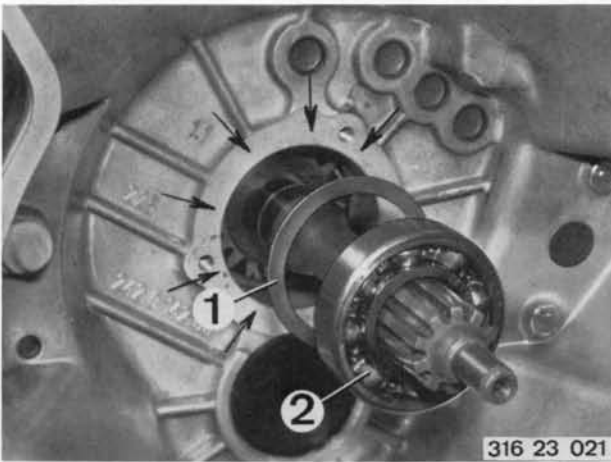

Drive input shaft grooved ball bearing out of transmission case.

Caution! Shim.

Install transmission case with light knocks and bolt to transmission cover.

Heat transmission case in area of input shaft and grooved ball bearing inner race.

Slide on shim (1) and grooved ball bearing (2).



Press on grooved ball bearing with Special Tool 23 1 000 until fit is tight.
Install shims and circlip.

23 11 101 REPLACING BACKUP LIGHT SWITCH

Disconnect wire at switch.
Unscrew switch.
Replace seal.

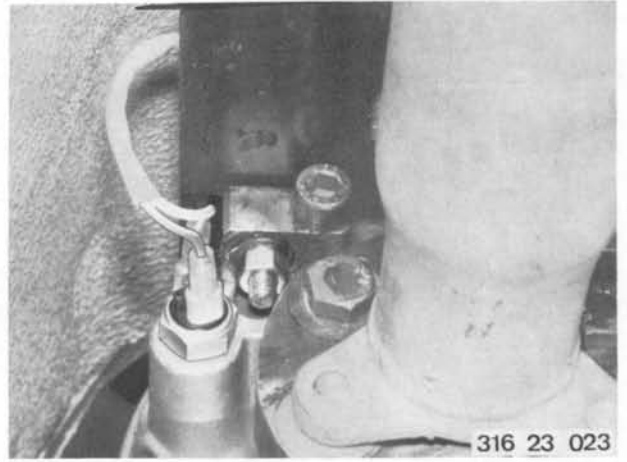

23 11 590 REMOVING AND INSTALLING CLUTCH RELEASE GUIDE SLEEVE

- Transmission Removed -

Lift out spring (1) and remove release lever (2) with pressure bearing (3).

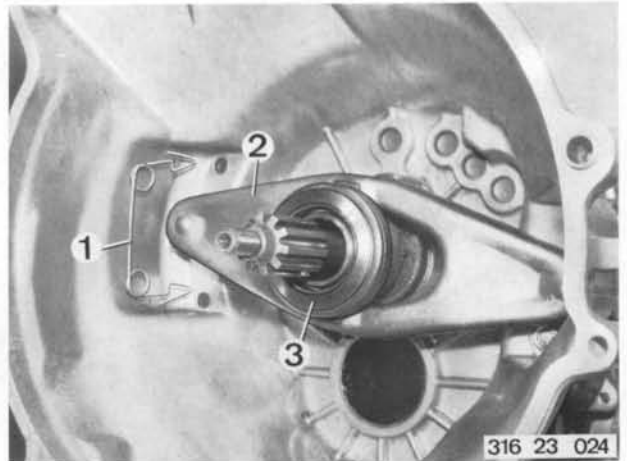

Installation Note! Fill lubrication groove (N) with Molykote BR 2-750.
Coat guides (F) and bearings (L) with DC 44 grease slightly.
Nonconformance could cause release bearing to stick on guide sleeve.

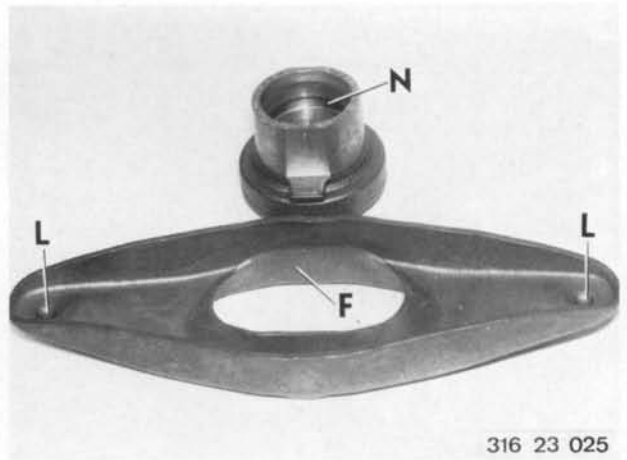

Remove guide sleeve.

Caution! Shims (4).

Installation Note! Replace gasket (5).

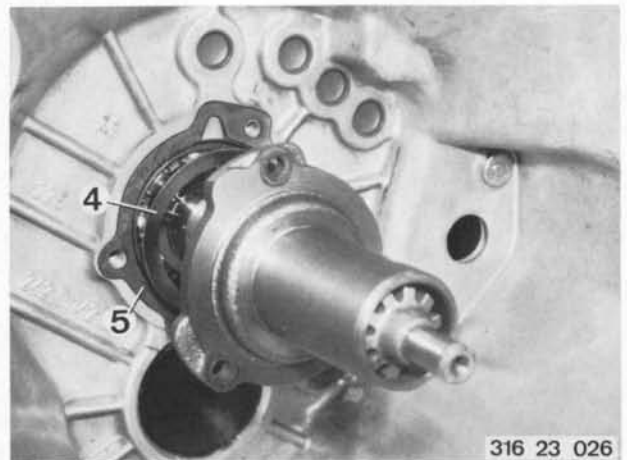

23 11 591 REPLACING CLUTCH RELEASE GUIDE SLEEVE

Remove guide sleeve - 23 11 590.

Installation Note! Measure distance A from case to grooved ball bearing.

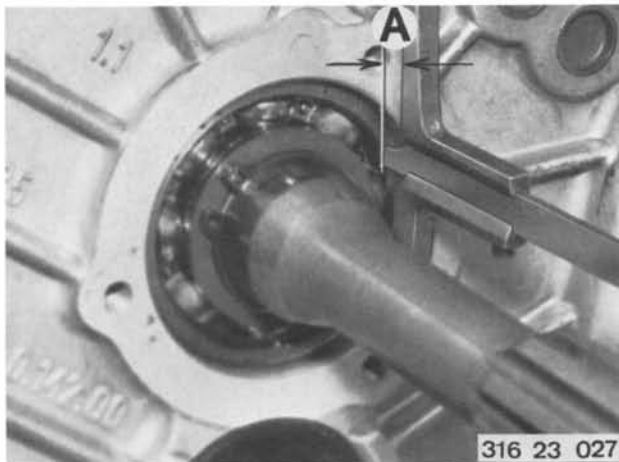

Determine shoulder height B of guide sleeve with gasket installed. Eliminate any and all play with shims.

Example: A 5.0 mm (0.197")
 - B 4.7 mm (0.185")

 0.3 mm (0.012") shim thickness

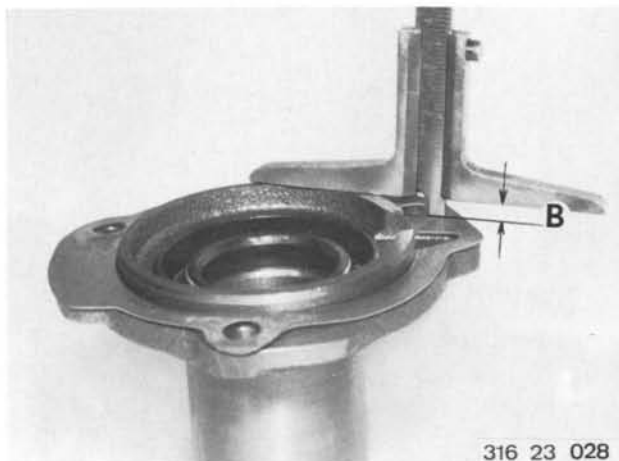

23 12 051 REPLACING OUTPUT SHAFT RADIAL OIL SEAL

Detach front propeller shaft and center bearing -
26 11 000.
Remove lockplate.

Installation Note! Jam lockplate in groove.

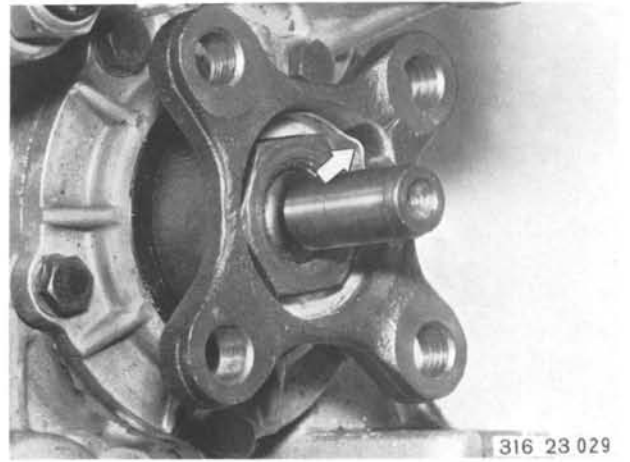

Install Special Tool 23 1 200.
Counterhold output flange with Special Tool 23 1 140.
Loosen collar nut 1) with Special Tool 23 1 210.
Pull off output flange.
If difficult to remove, apply Kukko extractor
00 8 500.

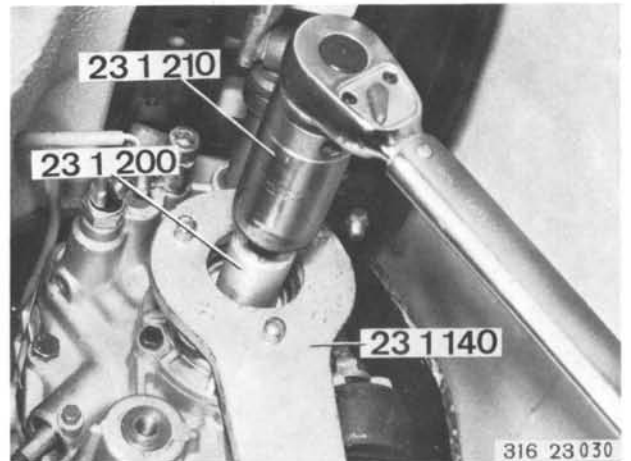

Extract radial oil seal with Special Tool 00 5 000.



Installation Note! Fill cavity between sealing lips
with grease.
Drive in radial oil seal with Special Tool 23 1 370.

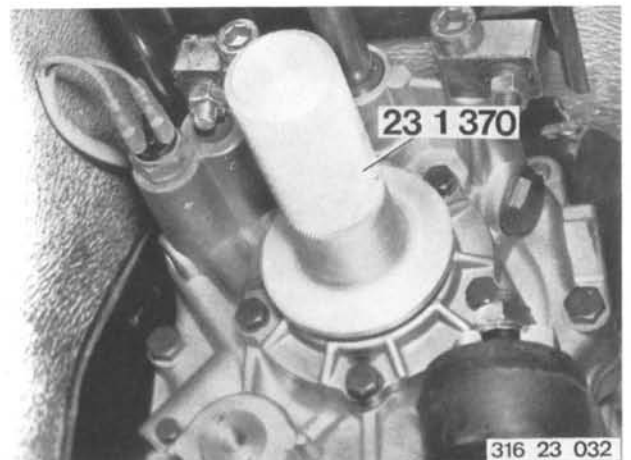

1) See Specifications for specified torque.

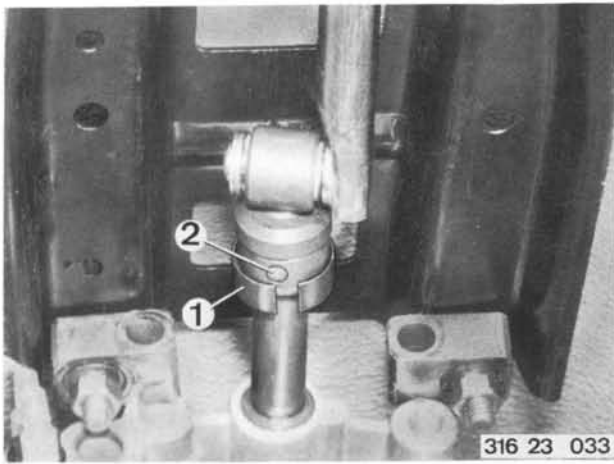

23 12 081 REPLACING SELECTOR SHAFT RADIAL OIL SEAL

Detach front propeller shaft and center bearing - 26 11 000.

Detach console at transmission.

Remove locating sleeve (1).

Drive out pin (2) upward.



Remove radial oil seal.

Installation Note! Fill cavity between sealing lips with grease. Drive in radial oil seal with an appropriate tube until flush.

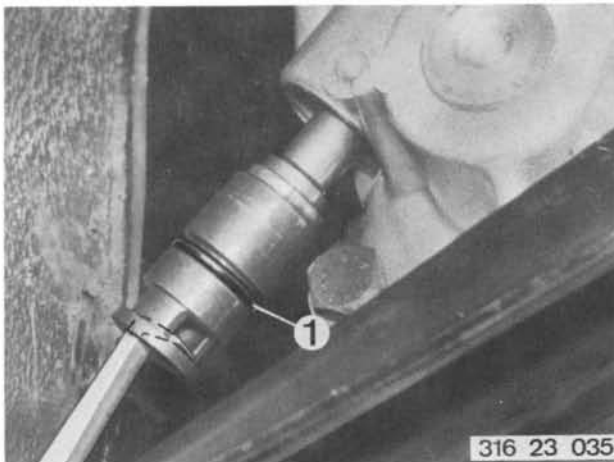

23 12 131 REPLACING SPEEDOMETER PINION BUSHING CORD SEAL

Knock or pull out bushing with an angled screwdriver.

Replace cord seal (1).

If oil leaks at radial oil seal, replace bushing.



23 12 521 REPLACING INPUT SHAFT RADIAL OIL SEAL - Guide Sleeve Removed -

Remove radial oil seal.

Installation Note! Drive in radial oil seal until it fits tight.

Open end faces transmission case.

Fill cavity between sealing lips with grease.

23 21 500 REMOVING AND INSTALLING INPUT AND OUTPUT
SHAFTS

- Transmission Case Detached -

Unscrew plug (1).
Remove spring (2) and lockpin (3).

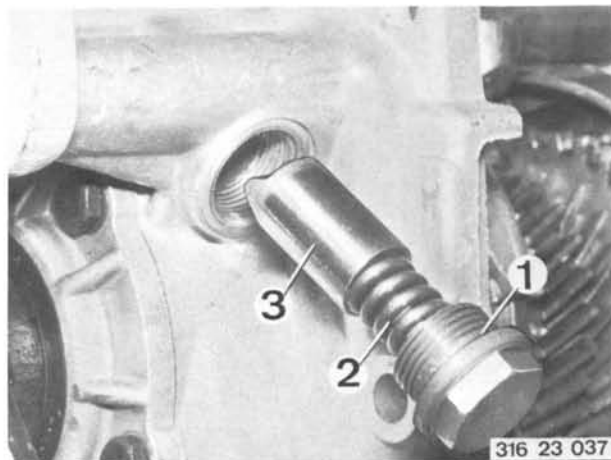

Move selector rod (4) to 3rd gear position.
Drive down dowel pin (5) carefully until selector
rod can be pulled out. If necessary, lift selector
rod slightly. (Note loose balls.)

Caution! Drive dowel pin between teeth of synchro-
nizing body. Dowel pin remains in lower part of
selector fork.

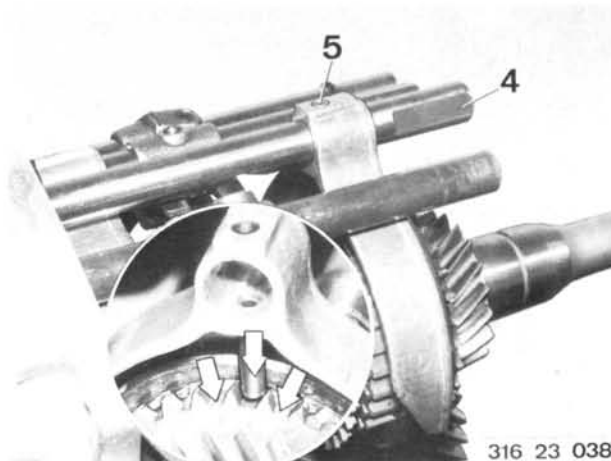

Remove locking sleeve (H).
Drive out pin (B).
Press selector fork into gearshift sleeve firmly
and remove selector shaft (6) by pulling out forward.
This requires swinging up selector finger.

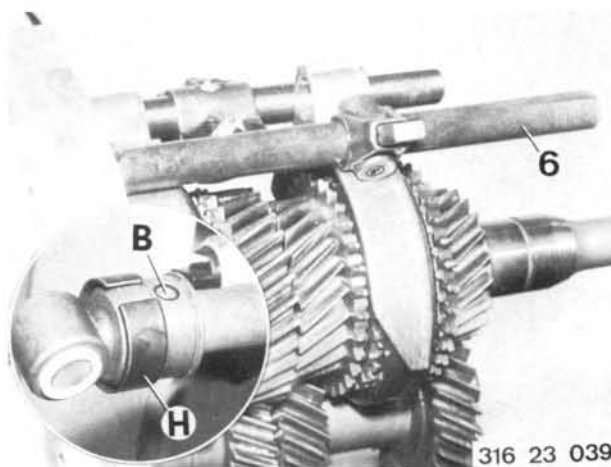

Move gearshift sleeve to neutral position. Take off
selector fork.
Drive dowel pin out of selector fork.

Installation Note!
Check selector fork for wear¹⁾ - 23 31 501.



1) See Specifications

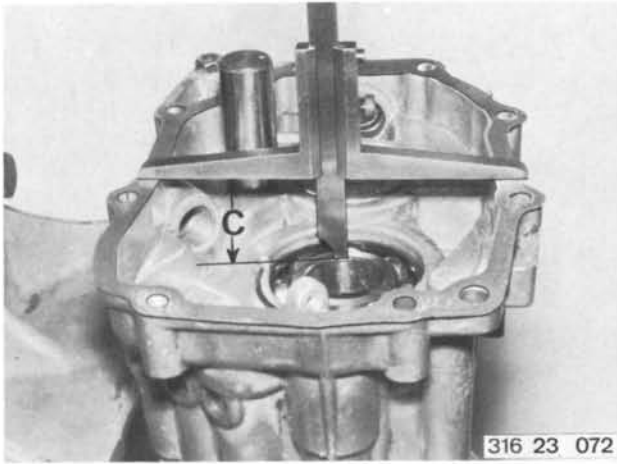

Press grooved ball bearing into transmission case cover until it fits tight.
Check distance C without gasket.

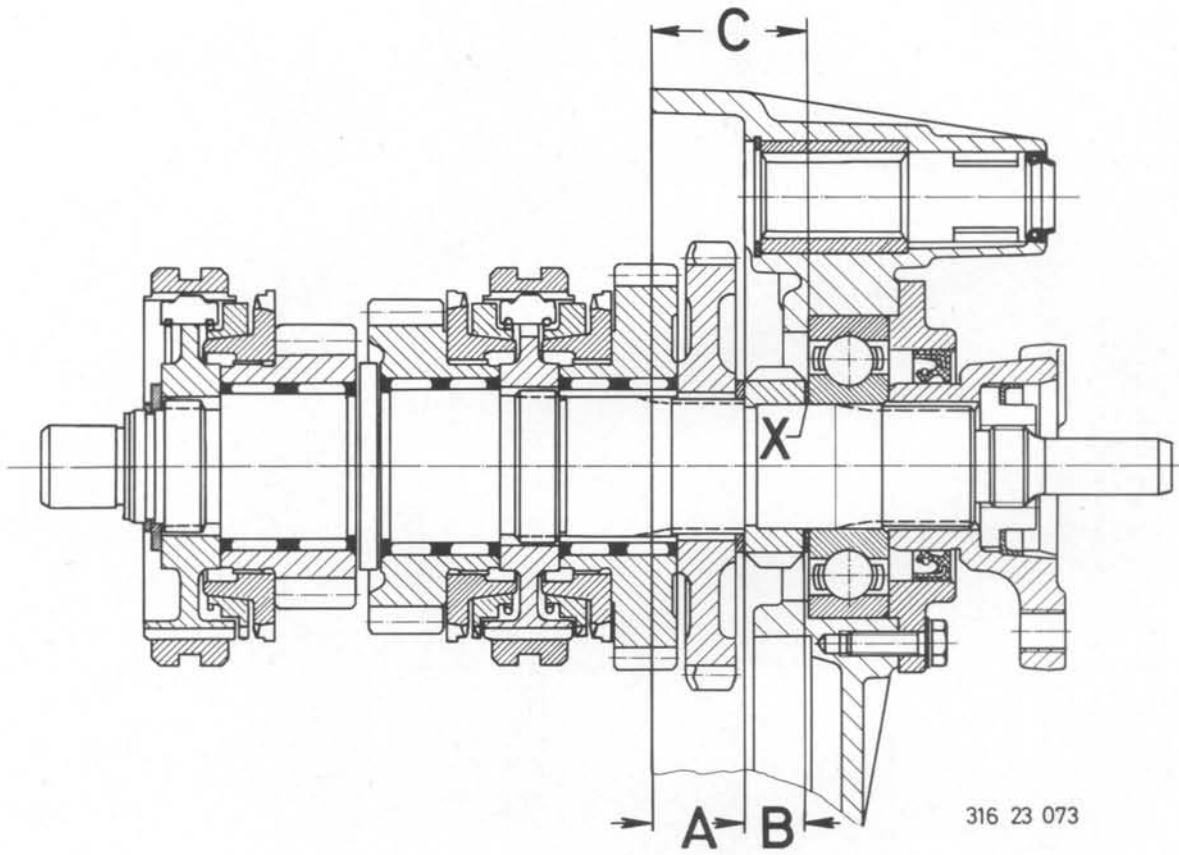

316 23 073

Determine thickness of shim X.

Example:	A	22.0 mm	(0.866")	nominal distance
	+ B	14.8 mm	(0.582")	
		36.8 mm	(1.448")	
		C	37.0 mm	(1.456")
		- 36.8 mm	(1.448")	
		X	0.2 mm	(0.008")

23 21 701 REPLACING ALL GROOVED BALL BEARINGS

- Transmission Removed -

Remove and install input and output shafts -
23 21 500.

A) Input Shaft

Install 1 mm (0.040") thick shim and grooved ball bearing in case.

Check distance A from sealing surface of case to grooved ball bearing.

B is electrically engraved in output shaft.
After determining actual distances A and B, the thickness of shim X can be read from the X column.

"A"	"B"	"X"
153.9 mm 6.059"	45 ... 50 mm	0.5 mm / 0.020"
	1.772 ... 1.968"	
	35 ... 40 mm	
	1.378 ... 1.575"	
153.8 mm 6.055"	45 ... 50 mm	0.4 mm / 0.016"
	1.772 ... 1.968"	
	35 ... 40 mm	
	1.378 ... 1.575"	
153.7 mm 6.051"	45 ... 50 mm	0.3 mm / 0.012"
	1.772 ... 1.968"	
	35 ... 40 mm	
	1.378 ... 1.575"	
153.6 mm 6.047"	45 ... 50 mm	0.2 mm / 0.008"
	1.772 ... 1.968"	
	35 ... 40 mm	
	1.378 ... 1.575"	
	25 ... 30 mm	0.6 mm / 0.024"
	0.984 ... 1.181"	
	25 ... 30 mm	
	0.984 ... 1.181"	
	25 ... 30 mm	0.5 mm / 0.020"
	0.984 ... 1.181"	
	25 ... 30 mm	
	0.984 ... 1.181"	
	25 ... 30 mm	0.4 mm / 0.016"
	0.984 ... 1.181"	
	25 ... 30 mm	
	0.984 ... 1.181"	

Place shim X on input shaft.

Drive input shaft bearing out of transmission case.

Caution! Shim.

Install case with light knocks and bolt to case cover.

Heat case in area of input shaft and bearing race.

Slide on shim (1) and grooved ball bearing (2).

Press on grooved ball bearing with Special Tool

23 1 000 until it fits tight.

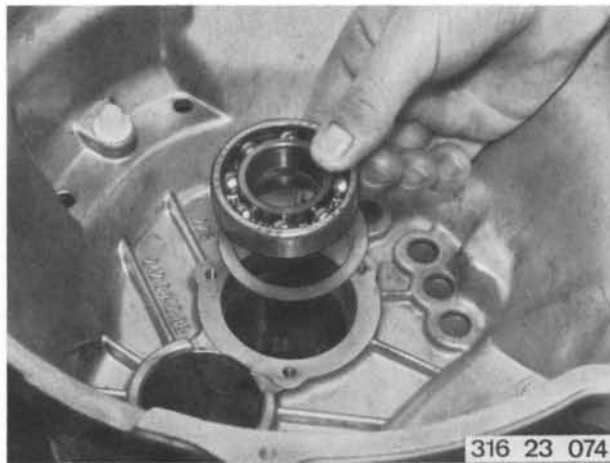

316 23 074

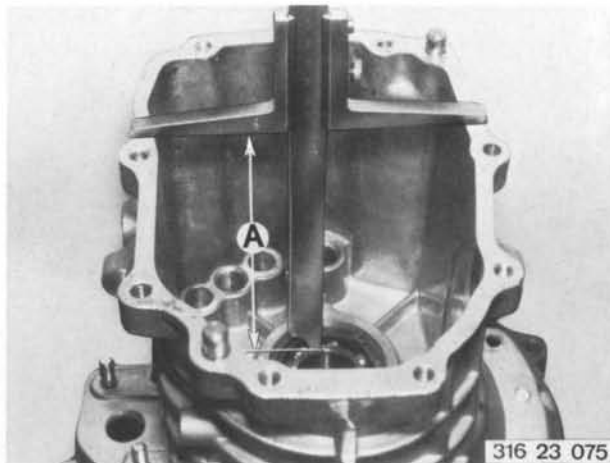

316 23 075

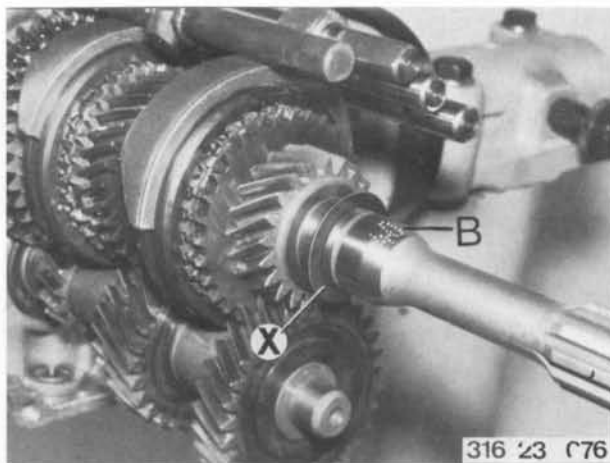

316 23 076

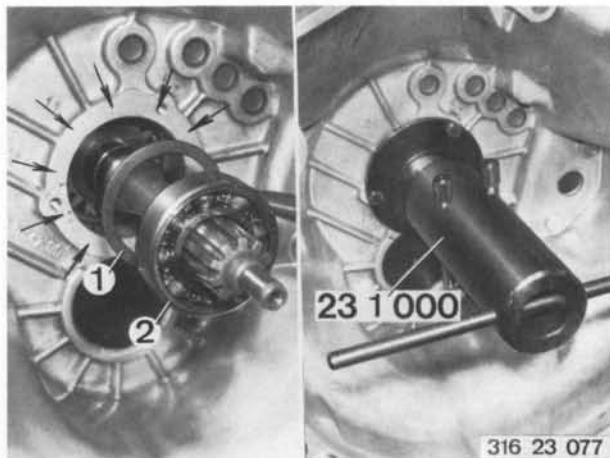

316 23 077

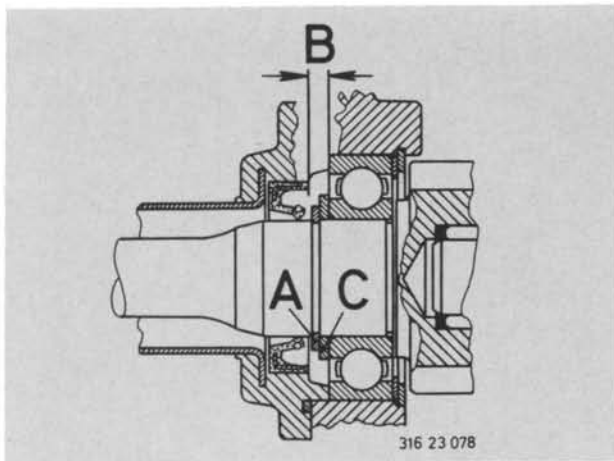

Check thickness A of circlip.
 Insert circlip into groove of input shaft.
 Check distance B from circlip to grooved ball bearing.
 Determine thickness of shim C.

Example: B 4.0 mm (0.1574")
 - A 2.0 mm (0.0787")

 C 2.0 mm (0.0787")

Install shim C.



B) Output Shaft

Check distance A from case cover to grooved ball bearing.

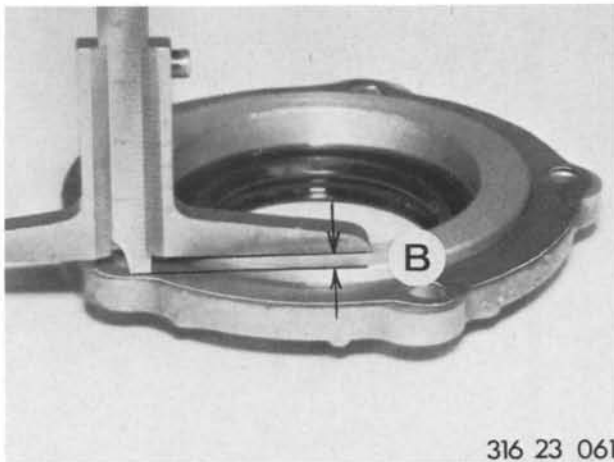

Measure shoulder height B of sealing cover with gasket installed.

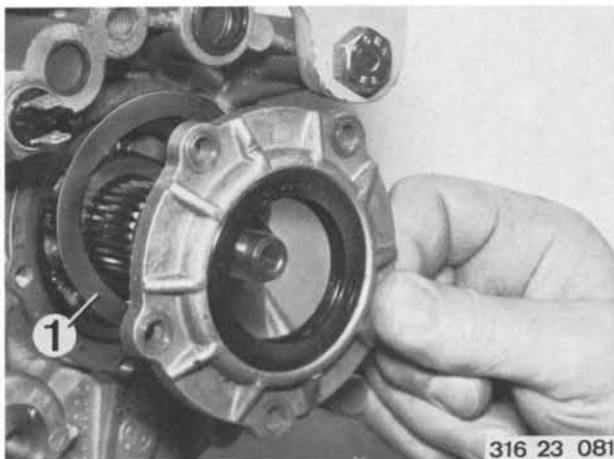

Caution! There must not be any play between grooved ball bearing outer race and sealing cover.
 Take up any play with shims (1).

Example: A 3.0 mm (0.118")
 - B 2.8 mm (0.110")

 0.2 mm (0.008") shim thickness

Secure sealing cover.
 Install and secure output flange.

C) Layshaft

Pull grooved ball bearing and inner race off of cylindrical roller bearing.

Caution! Shims.

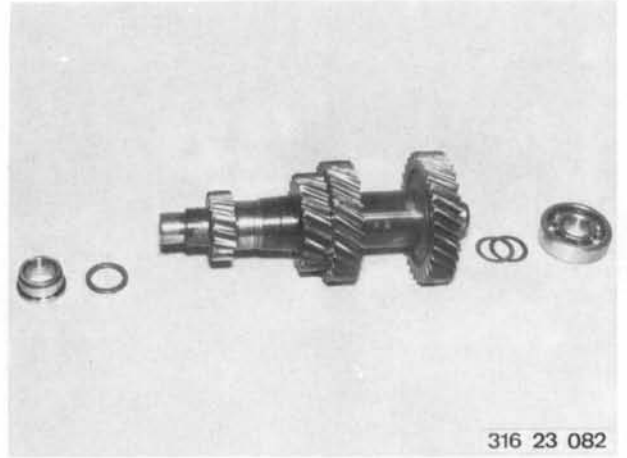

Pull cylindrical roller bearing out of transmission cover, or heat transmission cover to remove bearing.

Caution! Shims.

Installation Note! Small diameter end of roller cage faces transmission cover.

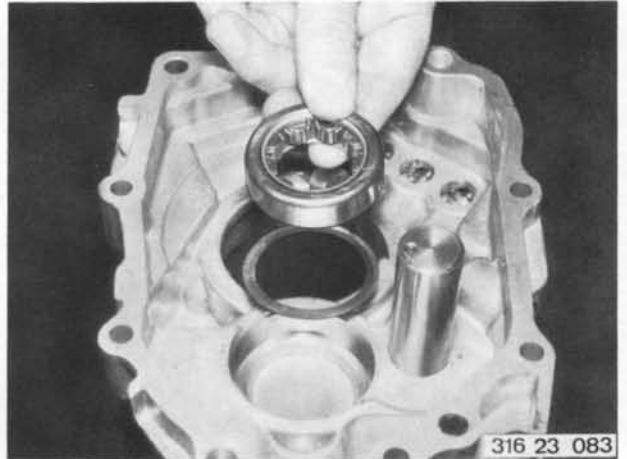

Check distance A from case sealing surface to circlip.



Install layshaft in transmission cover.
Measure height B of layshaft with gasket installed.
Remove layshaft.

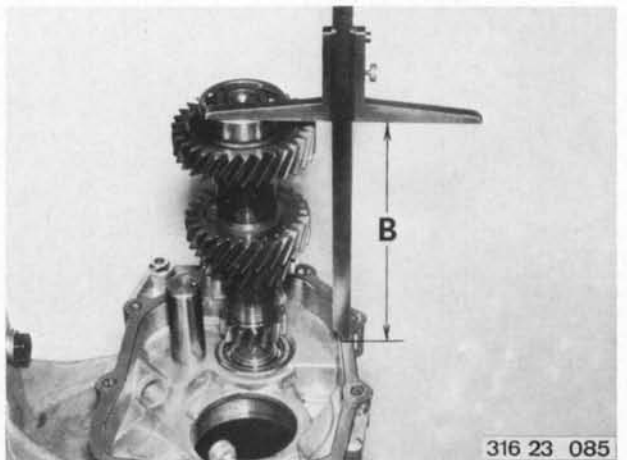

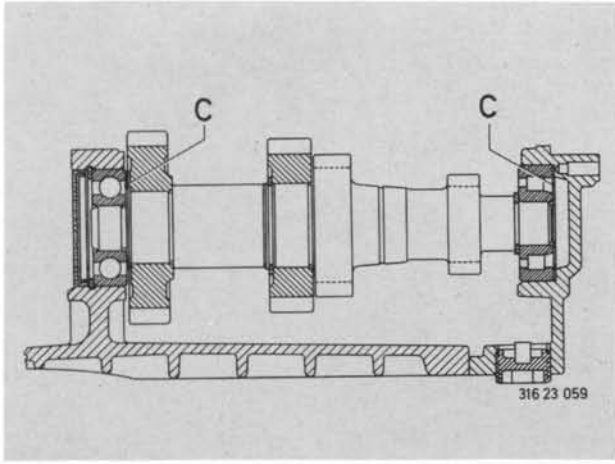

Determine thickness of shims C.

Example:

A	165.3 mm	(6.508")
- B	165.0 mm	(6.496")
<hr/>		
C	0.3 mm	(0.012")

Shims C can be used to change tooth engagement.

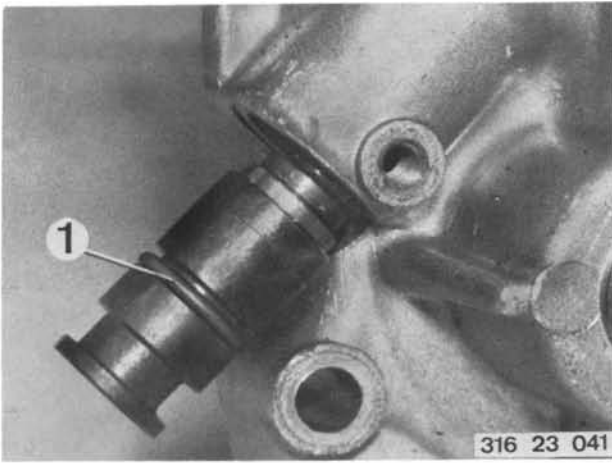

Remove bushing and speedometer pinion.

Installation Note! Check o-ring (1), replace if necessary.

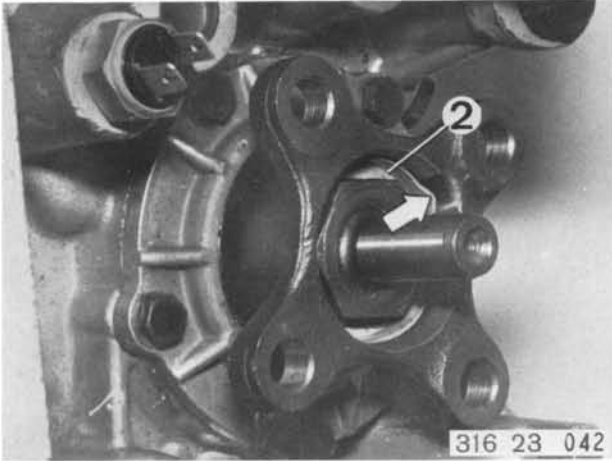

Remove lockplate (2).

Installation Note! Jam lockplate in groove.

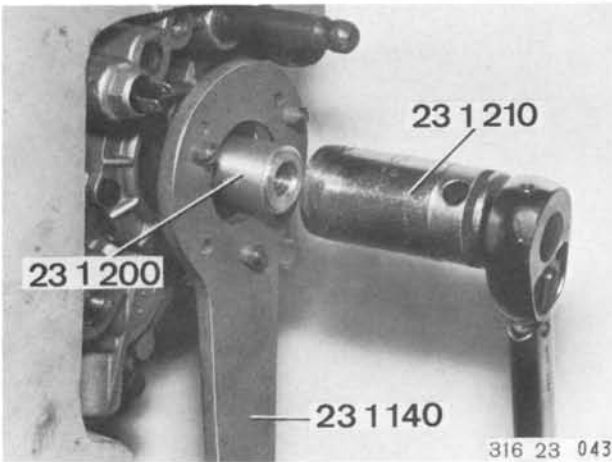

Install Special Tool 23 1 200.

Counterhold output flange with Special Tool 23 1 140.

Loosen collar nut 1) with Special Tool 23 1 210.

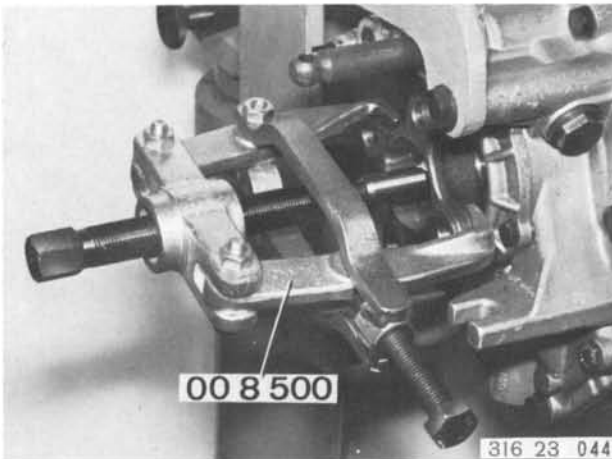

Pull off output flange.

If difficult to remove, use Kukko extractor 00 8 500.

1) See Specifications for specified torque.

Remove support ring.

Caution! Shims A.

Installation Note! Replace gasket (3).

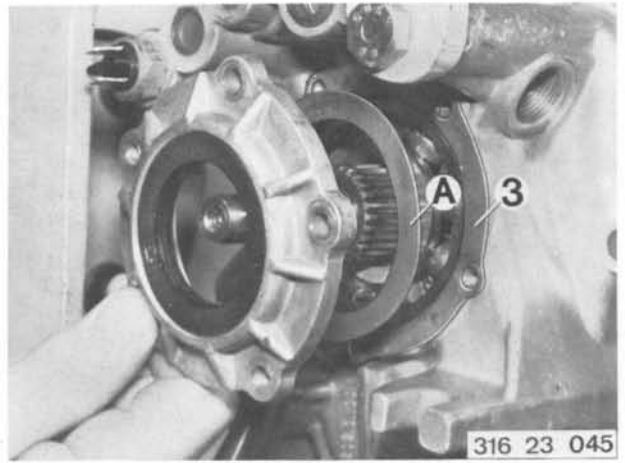

Caution! A 2 mm (0.078") thick strip of metal must be placed between 2nd and 3rd gear wheels, to prevent pressing off 2nd gear synchronizing body when removing output shaft grooved ball bearing.

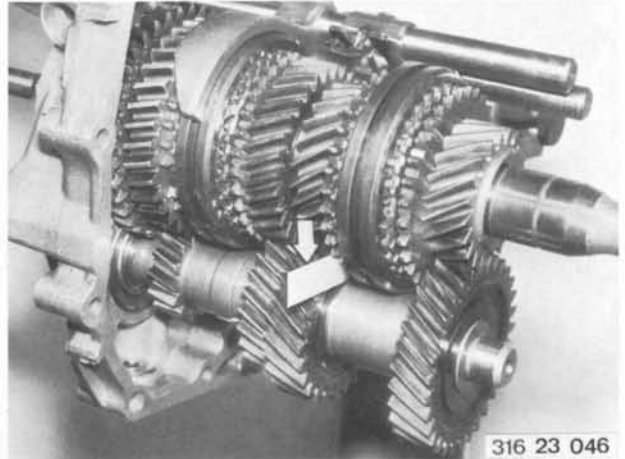

Extract grooved ball bearing from output shaft and out of transmission cover with Rillex 23 2 060.

Caution! Shims A.



Lift input and output shafts slightly.
Pull layshaft out of bearings.

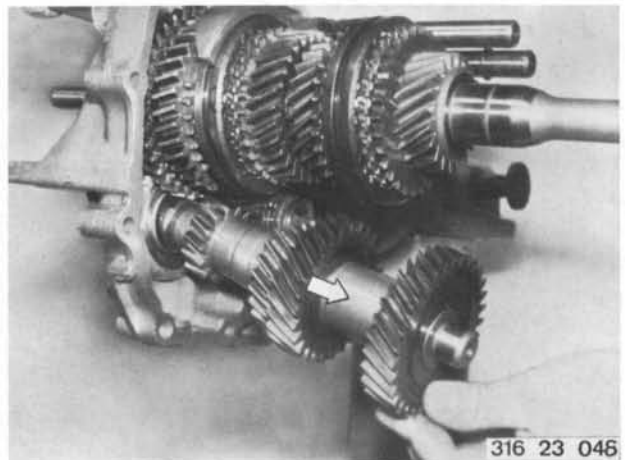

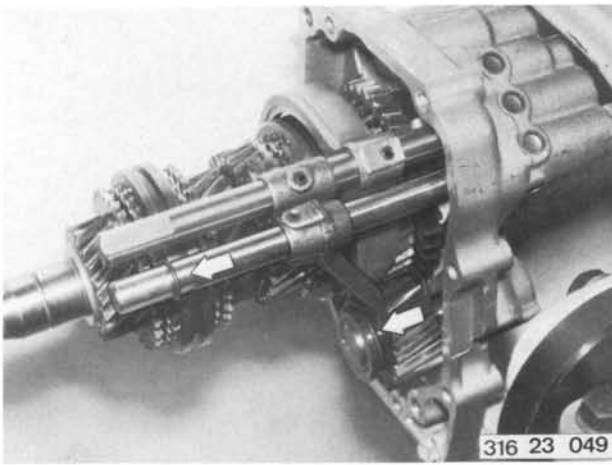

Pull selector rod with selector fork and reverse gear out of transmission cover.

Caution! Loose balls.

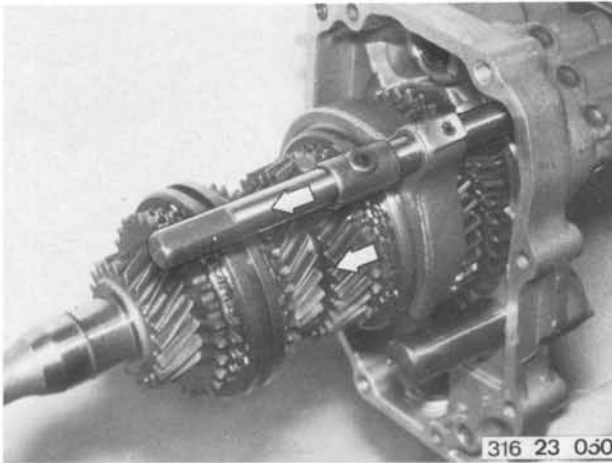

Take input and output shafts with selector rod and 1st/2nd gear selector fork out of transmission cover.

Caution! Loose balls.

Installation Note! Check selector forks for wear¹⁾, replace if necessary.

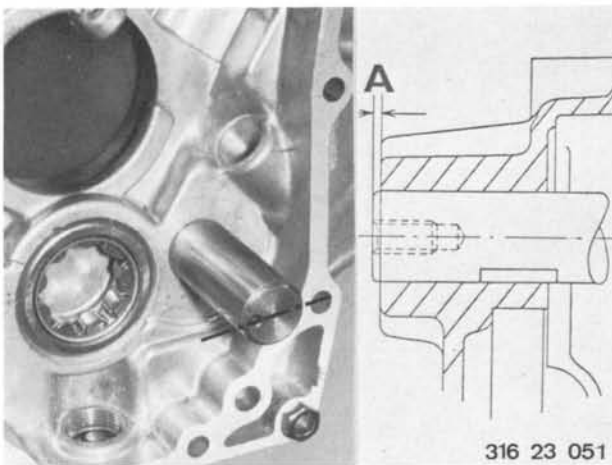

Replace a heavily worn reverse gear shaft.

Installation Note! Heat transmission cover to about 120° C (250° F).

Caution! Shaft is oval. When correctly installed, bore in shaft faces layshaft. Note installed length of shaft: A = 2 mm (0.079").

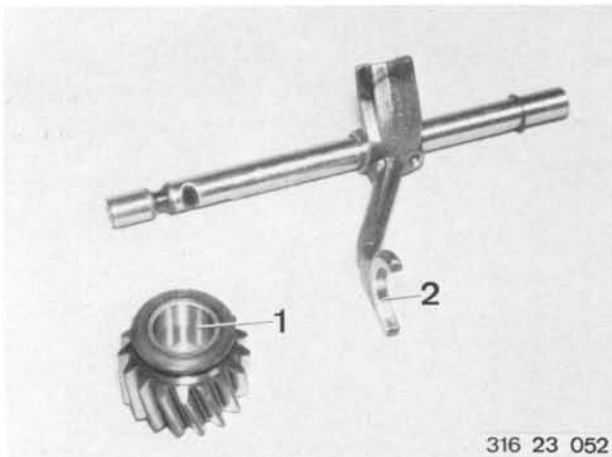

Replace reverse gear bushing. Ream open new bushing (1) to

$$21.3 \begin{matrix} + 0.073 \\ + 0.040 \end{matrix} \text{ mm } (0.838 \begin{matrix} + 0.003 \\ + 0.001 \end{matrix} \text{ in.}) \text{ dia.}$$

Check wear¹⁾ of selector fork (2), replace selector fork if necessary.

1) See Specifications

Remove backup light switch (1) and end cover (2).

Installation Note!

Press down locking balls with a screwdriver inserted through open holes.

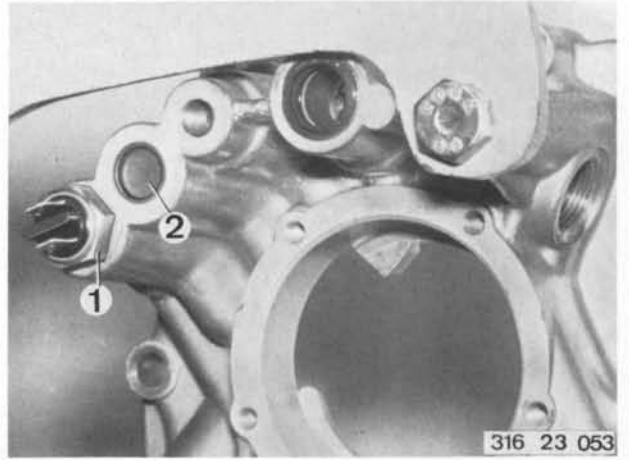

Installation Note!

Insert locking balls, press down and slide reverse gear selector rod with reverse gear wheel into case cover up to 1st lock.
Insert layshaft into cylindrical roller bearing.

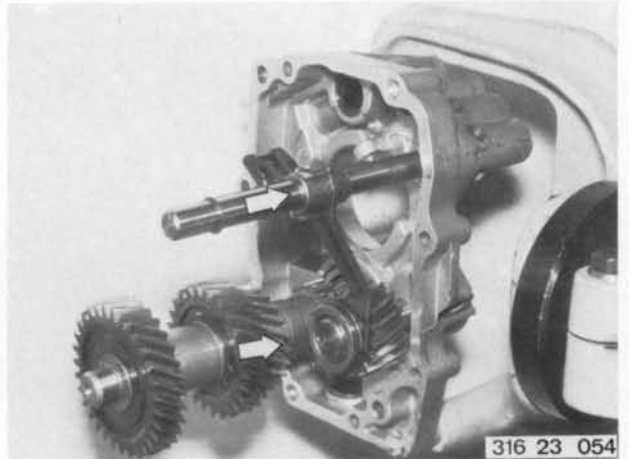

Install input and output shafts in transmission case cover.

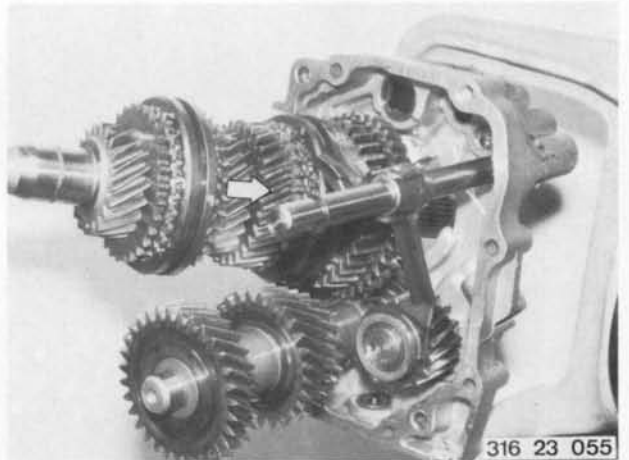

Insert shim of determined thickness X in front of speedometer gear. Install grooved ball bearing in case cover, but do not press in all the way.

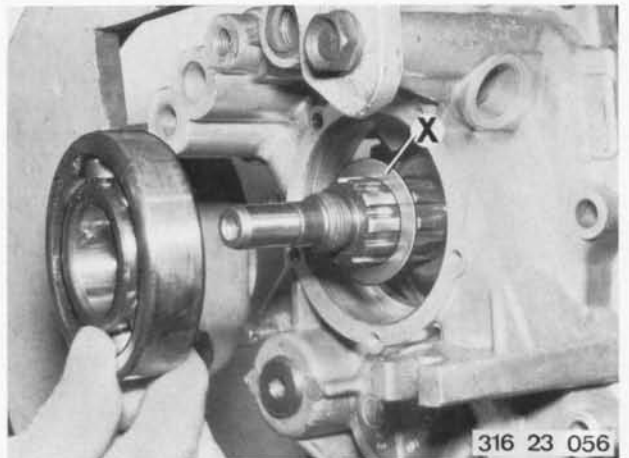

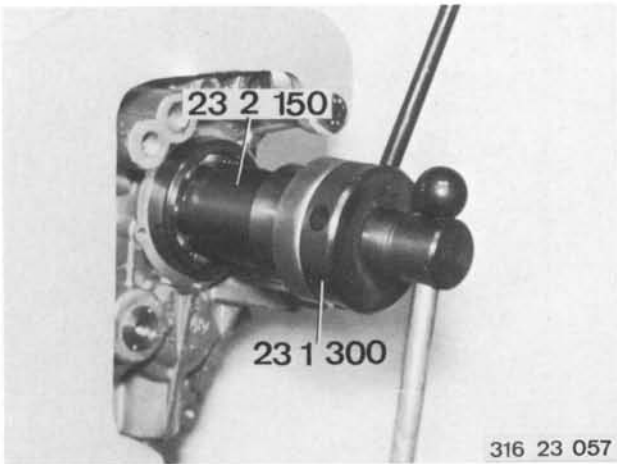

Press grooved ball bearing onto output shaft with Special Tools 23 2 150 and 23 1 300.

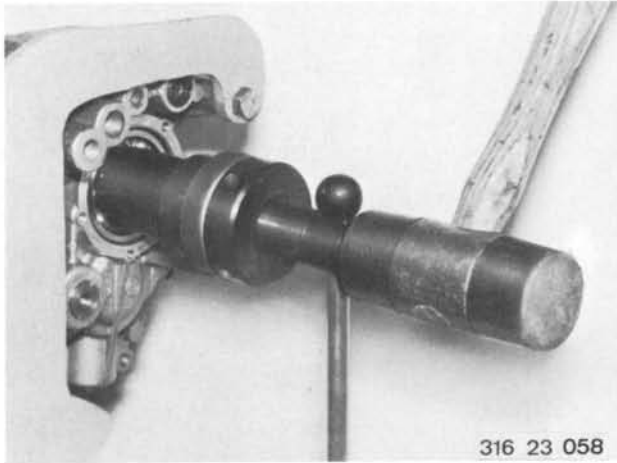

Apply light knocks until grooved ball bearing fits tight.

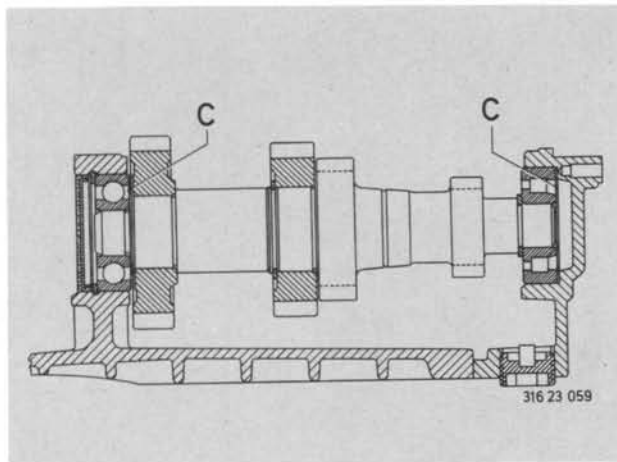

Check tooth engagement. Shims C will change tooth engagement.
Install speedometer bushing and drive.



Measure distance A from case cover to grooved ball bearing.

Measure shoulder height B of sealing cover with gasket installed.

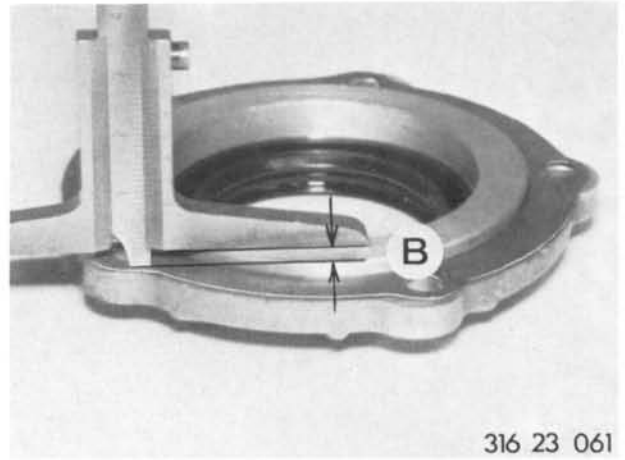

Caution! There can be no play between grooved ball bearing outer race and sealing cover. Take up any play with shims (1).

Example: A 3.0 mm (0.118")
 - B 2.8 mm (0.110")

 0.2 mm (0.008") shim thickness

Fasten sealing cover.
Fasten and secure output flange.

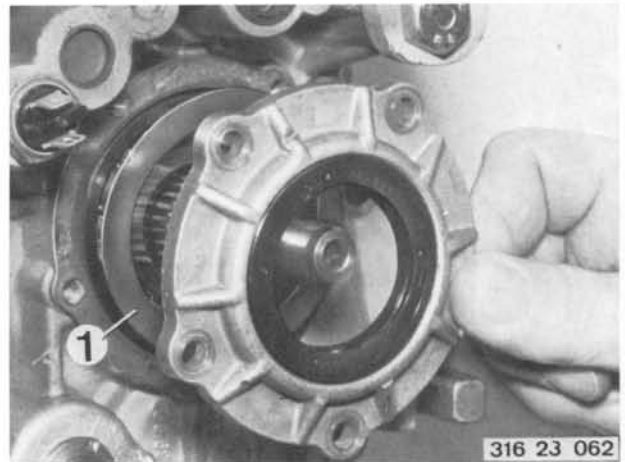

Drive out dowel pin.
Pull selector fork off of selector rod.

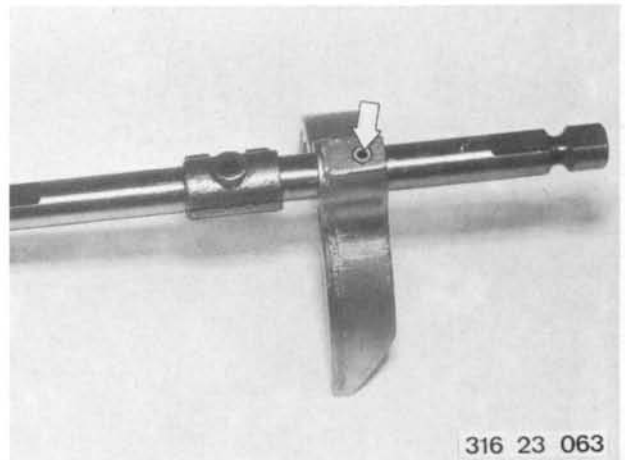

Insert 1st/2nd gear selector fork into gearshift sleeve.
Insert locating and locking balls.
Install selector rod.
Secure selector fork with dowel pin.

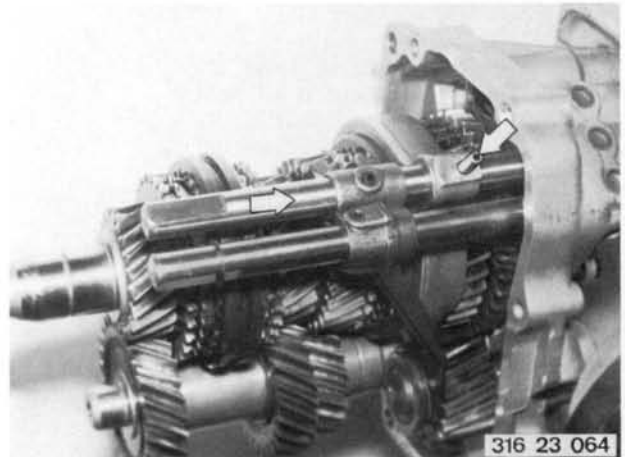

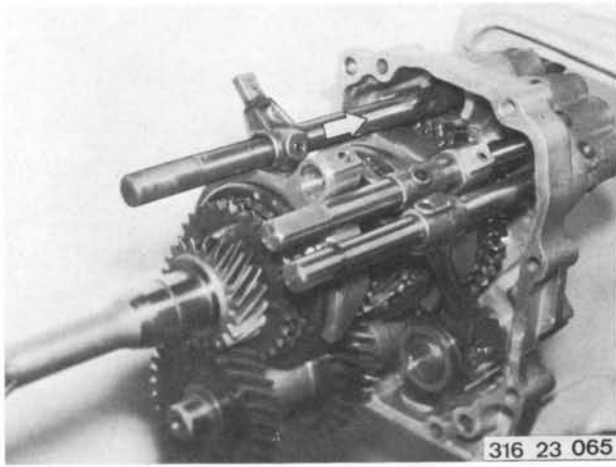

Insert 3rd/4th gear selector fork into gearshift sleeve.

Install selector shaft.

Caution! Note position of tapered bushing.

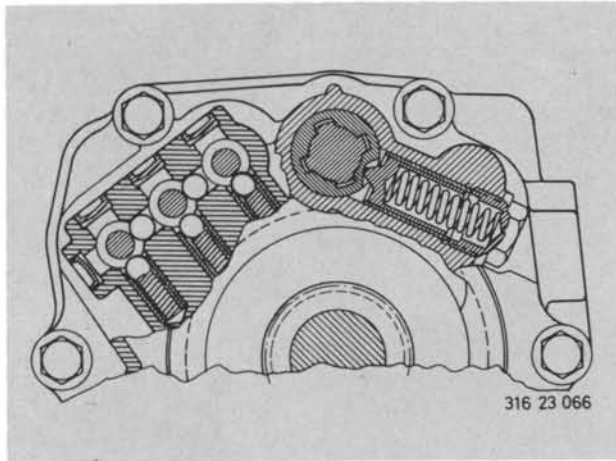

Install lockpin.

Note position of lockpin in tapered bushing.

Insert locating and locking balls.

Note arrangement of locating and locking balls.



Install 3rd/4th gear selector rod.

Secure selector fork with dowel pin.

Install cap and backup light switch.

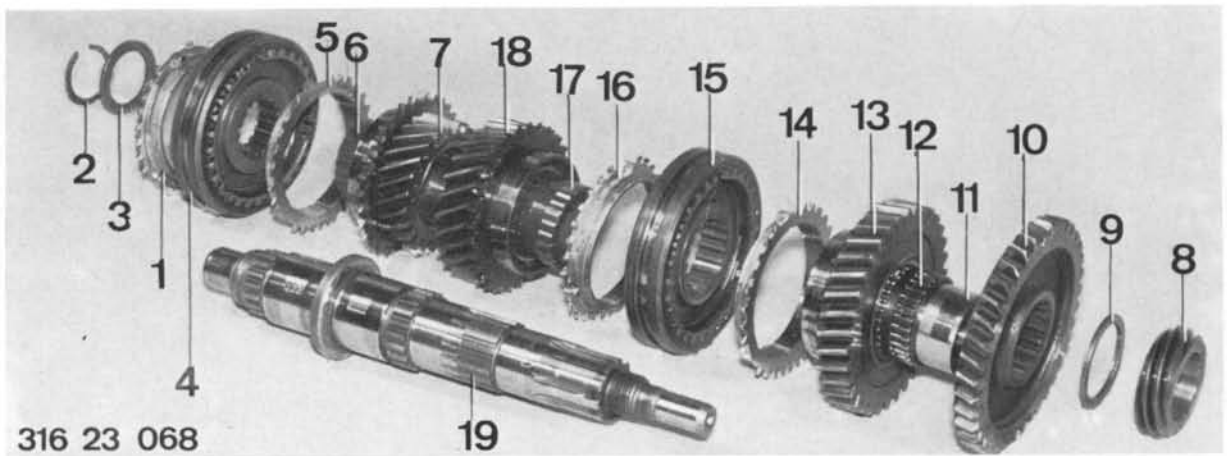

316 23 068

23 21 551 REPLACING OUTPUT SHAFT
 - Output Shaft Removed -

Remove 4th gear synchronizing ring (1) between input and output shafts.

Remove circlip (2).

Pull support disc (3), synchronizing body with sliding sleeve (4), 3rd gear synchronizing ring (5), needle bearing race (6) and 3rd gear wheel (7) off of output shaft.

Press speedometer worm (8), washer (9), reverse gear wheel (10), spacer (11), needle bearing race (12), 1st gear wheel (13), synchronizing ring (14), synchronizing body with sliding sleeve (15), synchronizing ring (16), needle bearing race (17) and 2nd gear wheel (18) off of output shaft (19).

Assemble output shaft.

Caution! Adjust axial play to 0 ... 0.09 mm (0 ... 0.003") with shim Y.

Place shim Y in front of reverse gear wheel.
 Press speedometer gear onto output shaft up to stop.
 Check axial play.

Check thickness B of speedometer gear.
 Press speedometer gear onto output shaft.

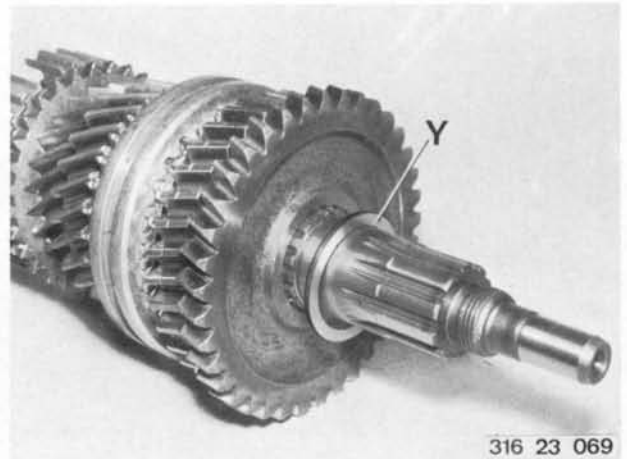

316 23 069

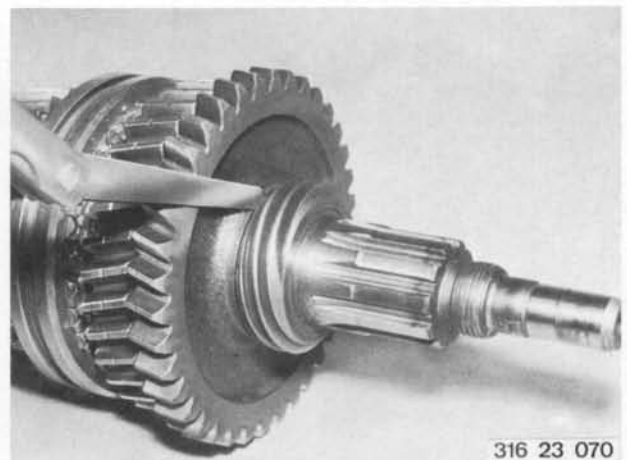

316 23 070

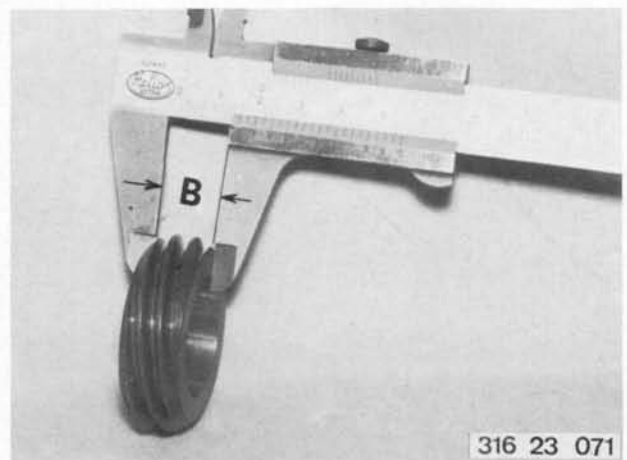

316 23 071

23 22 100 REMOVING AND INSTALLING SPEEDOMETER PINION

Detach speedometer shaft.
Carefully knock or pull out speedometer bushing with an angled screwdriver.
Check o-ring (1), replace if necessary.
Replace bushing, if radial oil seal is defective.

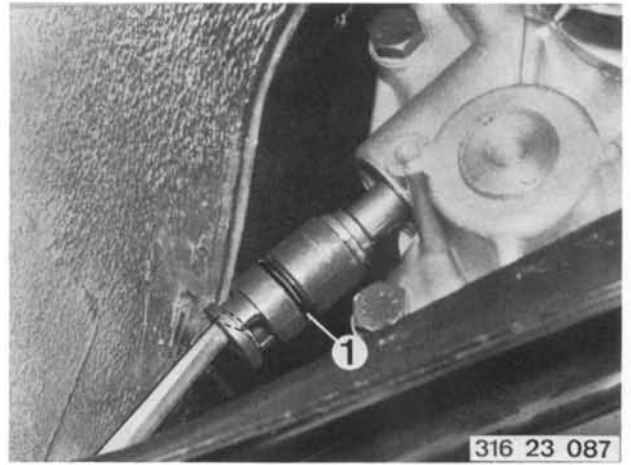

23 22 551 REPLACING 3RD AND 4TH GEAR WHEEL SETS

- Output Shaft Removed -

Pull input shaft with needle cage (1) and synchronizing ring (2) off of output shaft.

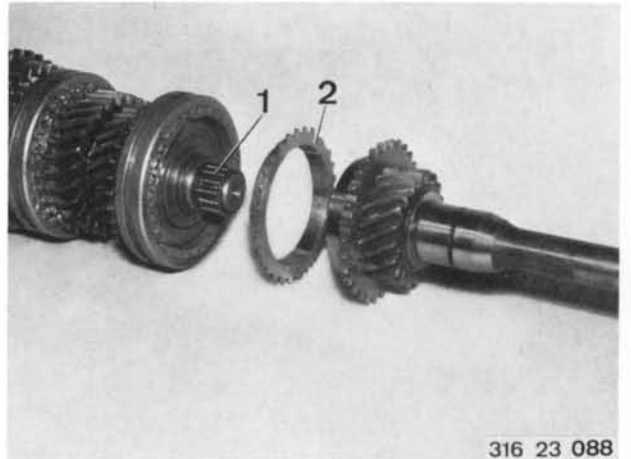

Remove circlip (3).
Pull off support disc (4), shim (5), guide sleeve (6), synchronizing ring (7) and 3rd gear wheel (8) with needle cage (9).

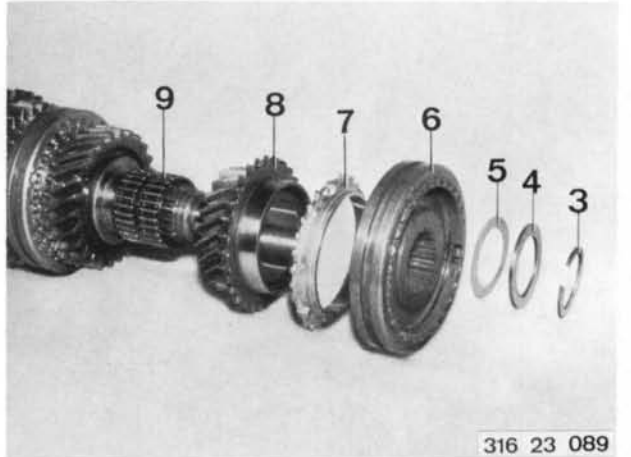

Installation Note! If needle bearing and spacer are also replaced, any play resulting must be taken up entirely.

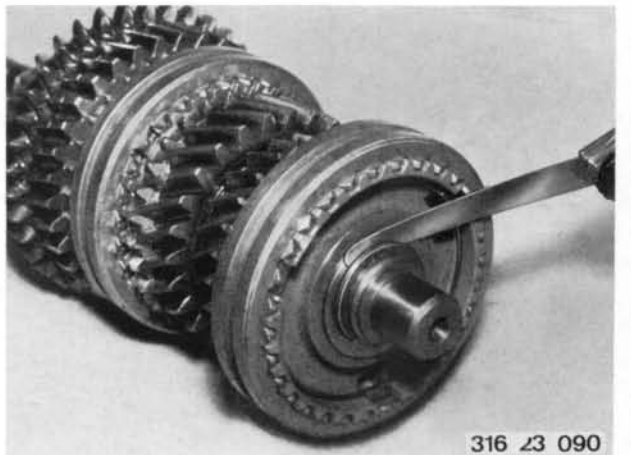

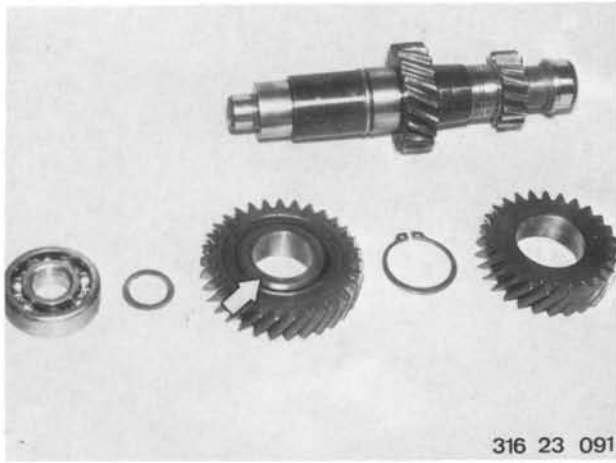

316 23 091

Press 4th gear wheel and grooved ball bearing off of layshaft.

Caution! Shims.

Remove circlip and press off 3rd gear wheel. Removal pressure about 10 tons, installing pressure about 7 tons.

Installation Note! Heat gear wheels to 120 ... 150° C (250 ... 300° F).

Caution! High collar on bore of 3rd and 4th gear wheel faces 2nd gear wheel.

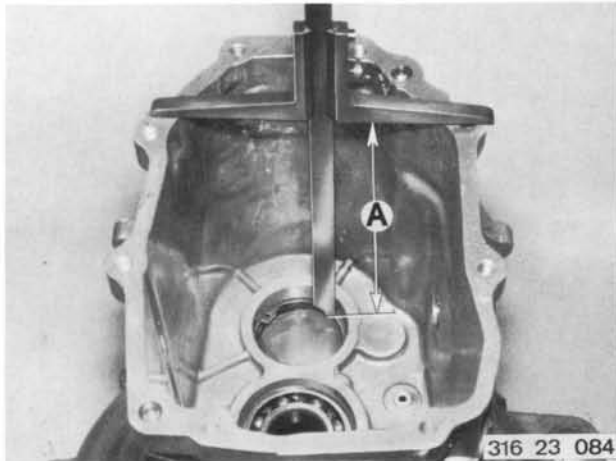

316 23 084

Check distance A from case sealing surface to circlip.

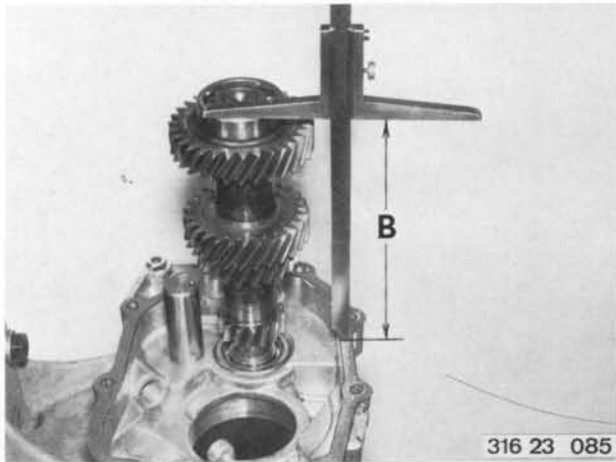

316 23 085

Install layshaft in transmission cover. Measure height B of layshaft with gasket installed. Remove layshaft. Determine thickness of shim.

Example:	A	165.3 mm	(6.508")
	- B	165.0 mm	(6.496")
		<hr/>	
		0.3 mm	(0.012") shim thickness

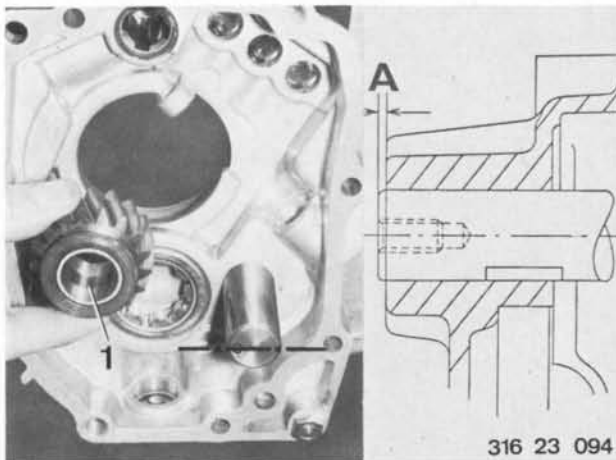

316 23 094

23 22 651 REPLACING REVERSE GEAR BUSHING

Press out bushing.

Installation Note! Ream out new bushing (1) to

21.3 + 0.073 mm (0.838 + 0.003 in.) diameter.
+ 0.040 mm + 0.001 in.

Check reverse gear shaft, replace if necessary. Heat transmission cover to about 120° C (250° F) to facilitate removal and installation.

Note installed distance A = 2 mm (0.078").

Shaft is oval. Bore in shaft must be at side.

23 23 503 REPLACING SYNCHRONIZING RINGS

Remove input and output shafts - 23 21 500.
Replace synchronizing rings when distance between synchronizing ring and clutch body is less than 0.8 mm (0.031").

Caution! Measurements made in area of stop tabs.
For new synchronizing rings this distance must be 1.0 mm (0.040").

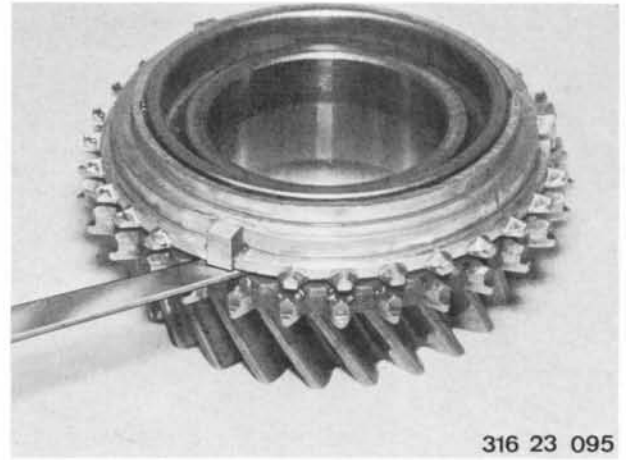

316 23 095

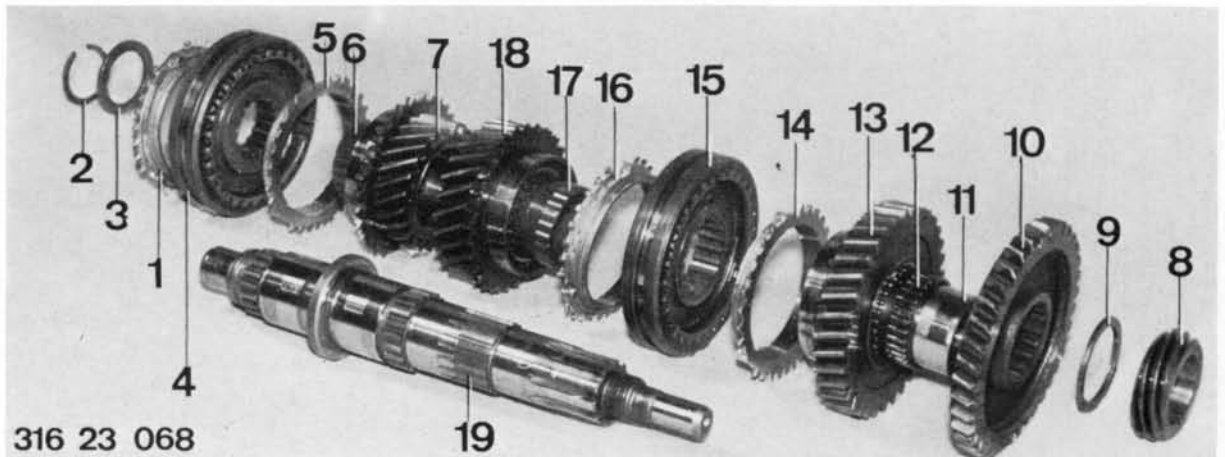

316 23 068

Remove 4th gear synchronizing ring (1) between input and output shafts.

Remove circlip (2).

Pull support disc (3), synchronizing body with sliding sleeve (4), 3rd gear synchronizing ring (5), needle cage (6) and 3rd gear wheel (7) off of output shaft.

Press speedometer worm (8), plain washer (9), reverse gear wheel (10), spacer (11), needle cage (12), 1st gear wheel (13), synchronizing ring (14), synchronizing body with sliding sleeve (15), synchronizing ring (16), needle cage (17) and 2nd gear wheel (18) off of output shaft (19).

23 31 501 REPLACING 1ST/2ND AND 3RD/4TH GEAR
SELECTOR FORKS

Remove input and output shafts - 23 21 500.
Check selector forks for wear. 1)

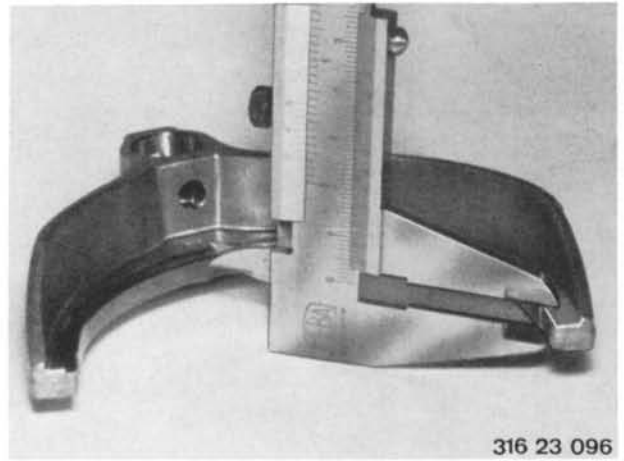

23 31 721 REPLACING ALL SLIDING BLOCKS

Remove input and output shafts - 23 21 500.
Disassemble output shaft - 23 23 503.
Press sliding sleeve off of synchronizing body.

Installation Note! Slide on sliding sleeve with
flat teeth over pressure pads.

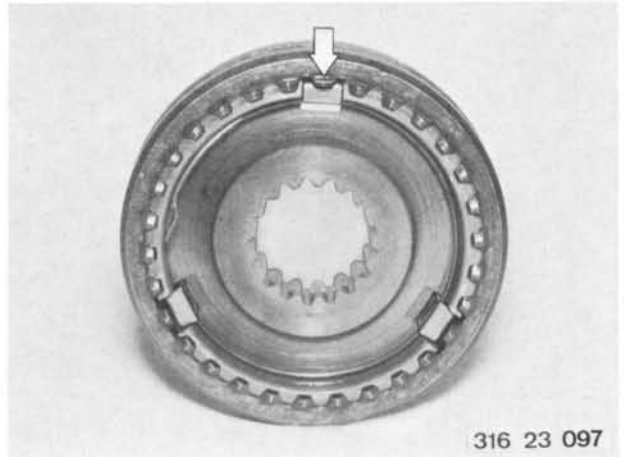

Offset hooked ends of synchronizing springs in a
longitudinal groove to each other.
Attach pressure pads to synchronizing springs.

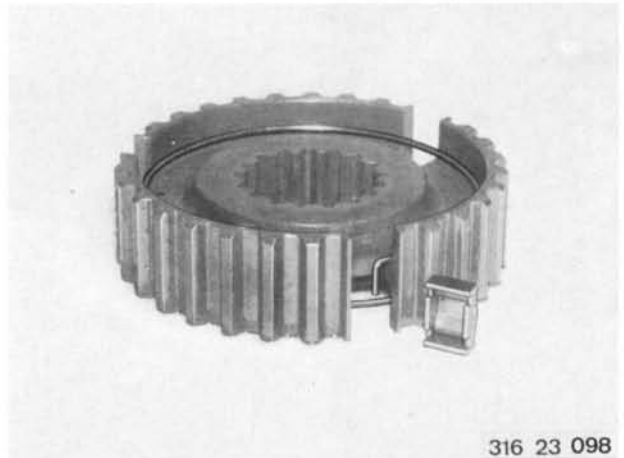

23 31 751 REPLACING REVERSE GEAR SELECTOR FORK

Remove input and output shafts - 23 21 500.
Measure amount of wear on selector forks. 1)
Drive out dowel pin.

Installation Note! Crank on selector fork faces
ball grooves or milled surface.



1) See Specifications