

31 Front Axle

	Page
Specifications .....	31- 0/3
31 10 000 Removing and Installing Front Axle Assembly .....	10/1
31 11 001 Replacing Front Axle Support .....	11/1
31 12 000 Removing and Installing Control Arm .....	12/1
631 Replacing Control Arm Rubber Mount - Control Arm Removed - .....	12/2
31 20 004 Adjusting Wheel Bearing Play .....	20/1
31 21 009 Checking Wheel Hub Lateral Runout .....	21/1
050 Removing and Installing End Cap .....	21/1
100 Removing and Installing Wheel Hub .....	21/1
561 Replacing Wheel Hub .....	21/2
621 Replacing Taper Roller Bearings and Shaft Seal .....	21/2
31 31 000 Removing and Installing Coil Spring/Shock Absorber Strut .....	31/1
031 Replacing Coil Spring/Shock Absorber Strut .....	31/2
31 32 001 Replacing Shock Absorber .....	32/1
31 33 000 Removing and Installing Strut Support Bearing .....	33/1
051 Replacing Outer Tube .....	33/2
100 Removing and Installing Coil Spring .....	33/2
101 Replacing Coil Spring .....	33/2
31 35 000 Removing and Installing Stabilizer .....	35/1

Front Axle

SPECIFICATIONS

Model	320 i	320 i A
Track width (max. axle load)	mm (in.)	1384 (54.488)
Upward wheel travel	mm (in.)	83 ( 3.268)
Downward wheel travel	mm (in.)	109 ( 4.291)
Axial wheel bearing play <sup>1)</sup>	mm (in.)	0 ... 0.05 (0 ... 0.002)
Max. wheel hub lateral runoff at brake disc (taken up in bearing seat)	mm (in.)	0.05 (0.002)
Wheel bearing lubrication between outer and inner wheel bearings	grams	50 Shell Retinax A
Wheel hub end cap	grams	20 Shell Retinax A
Knuckle ball pivot torque in joint	Nm/kpm(ft lbs)	1.5 ... 5 / 0.15 ... 0.5 (1 ... 3.5)
Max. axial spring travel of knuckle ball pivot in joint at maximum wear	mm (in.)	1.4 (0.055)
<u>Coil Springs</u> <sup>2)</sup>		
Relaxed length	mm (in.)	400.5 (15.768)
Wire gage diameter	mm (in.)	13.2 ( 0.520)
Outside coil diameter	mm (in.)	165.2 ± 1.5 (6.504 ± 0.059)
Relaxed pitch	mm (in.)	72.6 (2.858)
Color code		blue or red, white and green depending on coil spring force along entire length of spring
Coil spring force, color code red	N/kp(lbs.)	3060 ... 3145 / 312 ... 320 (688 ... 705)
color code white	N/kp(lbs.)	3146 ... 3230 / 321 ... 329 (707 ... 725)
color code green	N/kp(lbs.)	3231 ... 3315 / 330 ... 338 (727 ... 745)

1) Note assembly instructions.

2) Only use coil springs of the same coil spring force on any one axle, as well as springs with the same color code front and rear (max. difference between front and rear coil spring force is only 1 class).

Model

320 i

320 i A

Auxiliary Spring

Length

mm (in.)

95 ± 1 (3.740 ± 0.040)

Stabilizer

Outside diameter

mm (in.)

23 (0.905)

Shock Absorber

Make

Fichtel & Sachs

Installed length A (extended)

mm (in.)

660 ± 3 (25.984 ± 0.118)



a

Installed length B (compressed)

mm (in.)

480 (18.898)/5 (0.197) reserve

Code letter on top hexagon

Oil filling between spring strut and shock absorber

brand-name engine oil SAE 30

Oil quantity

cm<sup>3</sup> (in.<sup>3</sup>)

30 (1.8)

Shock Absorber Settings

Test stroke

mm (in.)

100 (3.937)

100 (3.937)

Speed

rpm

25

75

100

Traction stage

N/kp(lbs)

110 / 11.2 (25)

440 / 44.9 (99)

640 / 65.2 (144)

Compression stage

N/kp(lbs)

110 / 11.2 (25)

330 / 33.6 (74)

450 / 49.9 (101)

Front AxleSPECIFICATIONS

Model

320 i

320 i A

Special Version  
=====Coil Spring  
1)

- for cars with air conditioner -

Relaxed length	mm (in.)	406 (15.984)
Wire gauge diameter	mm (in.)	13.2 (0.520)
Outside coil diameter	mm (in.)	104.2 ± 1.5 (4.102 ± 0.059)
Relaxed pitch	mm (in.)	73.8 (2.905)
Color code		violet as well as red, white or green depending on coil spring force along entire length of spring
Coil spring force, color code red	N/kp(lbs)	3060 ... 3145 / 312 ... 320 (688 ... 705)
color code white	N/kp(lbs)	3146 ... 3230 / 321 ... 329 (707 ... 725)
color code green	N/kp(lbs)	3231 ... 3315 / 330 ... 338 (727 ... 745)

1) Only use coil springs of the same coil spring force on any one axle, as well as springs with the same color code front and rear (max. difference between front and rear coil spring force is only 1 class).

Torque Specifications in Nm / kpm (ft. lbs.)

Spring/absorber strut to support bearing	78 ... 86 / 7.8 ... 8.6 (57 ... 62)	Steering box to front axle support	M 8 25 ... 28 / 2.5 ... 2.8 (18 ... 20)
Support bearing to wheelhouse	22 ... 24 / 2.2 ... 2.4 (16 ... 17)		M 10 49 ... 54 / 4.9 ... 5.4 (35 ... 39)
Spring/absorber strut threaded ring	120 ... 140 / 12 ... 14 (87 ... 101)	Tie rods to steering box	70 ... 78 / 7.0 ... 7.8 (50 ... 56)
Joint to steering knuckle	60 ... 70 / 6.0 ... 7.0 (44 ... 50)	Tie rod counter-nuts	55 ... 65 / 5.5 ... 6.5 (40 ... 47)
Control arm to front axle support*)	81 ... 90 / 8.1 ... 9.0 (58 ... 65)	Tie rods to steering knuckle	35 ... 40 / 3.5 ... 4.0 (25 ... 29)
Front axle support to engine carrier	43 ... 48 / 4.3 ... 4.8 (31 ... 35)	Stabilizer to control arm*)	70 ... 90 / 7.0 ... 9.0 (50 ... 65)
Brake disc to wheel hub	M 6 4 ... 5 / 0.4 ... 0.5 (3 ... 3.5)	Stabilizer holder*)	47 ... 52 / 4.7 ... 5.2 (34 ... 37)
Brake disc guard	9 ... 10 / 0.9 ... 1.0 (6.5 ... 7)		

\*) See Page 32-0/3 for normal lengths.

31 10 000 REMOVING AND INSTALLING FRONT AXLE ASSY.

Remove and install front wheels - 36 10 340.  
Detach left and right coil spring/shock absorber  
strut brackets.

Installation Note! Place brackets in locks.  
Tighten to specified torque. 1)

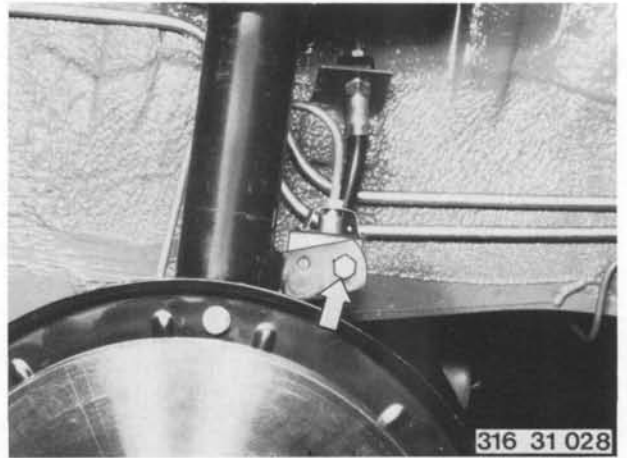

Detach left and right calipers.  
Brake line remains connected.

Installation Note! Tighten to specified torque<sup>1)</sup>.

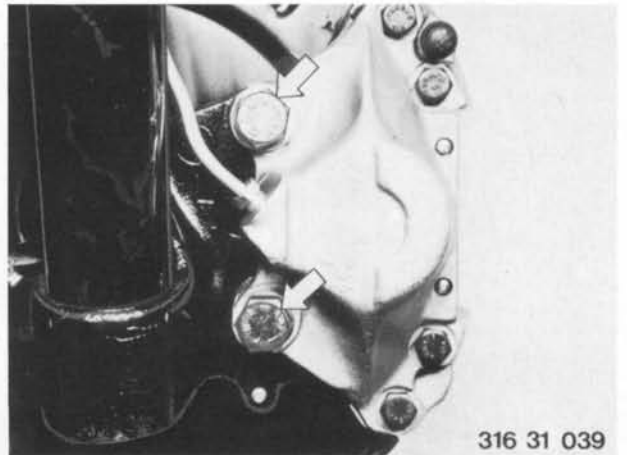

Detach left and right stabilizer holders.

Installation Note! Replace self-locking nuts.  
Check rubber bearings, replace if necessary.  
Tighten to specified torque. 1)

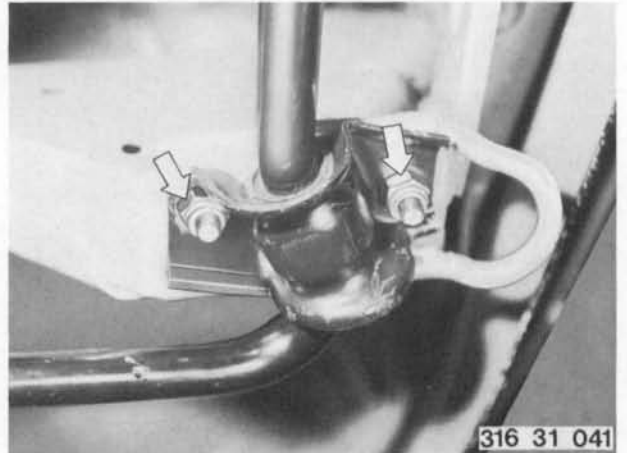

Detach left engine mount (1).  
Detach engine damper (2).

Installation Note! Replace self-locking nuts.  
Check engine damper's rubber bearing, replace if  
necessary.  
Shoulder (3) of engine mount must engage in opening  
provided.  
Tighten to specified torque<sup>1)</sup>.

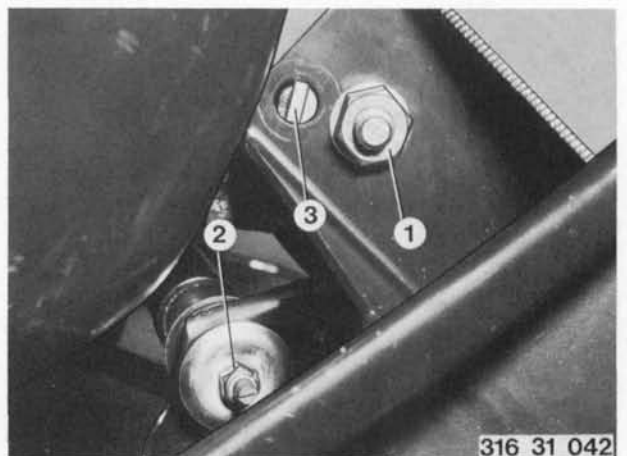

1) See Specifications

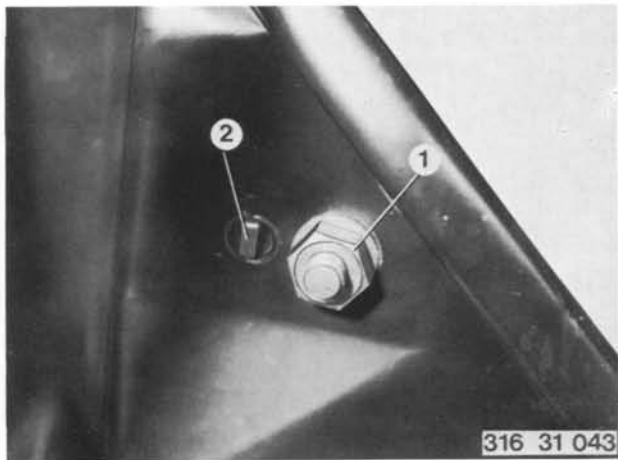

Detach right engine mount (1).

Installation Note! Tighten to specified torque<sup>1)</sup>.  
Make sure that shoulder (2) of engine mount engages  
in opening provided.



Detach left and right coil spring/shock absorber  
struts at wheelhouse.

Installation Note! Tighten to specified torque<sup>1)</sup>.

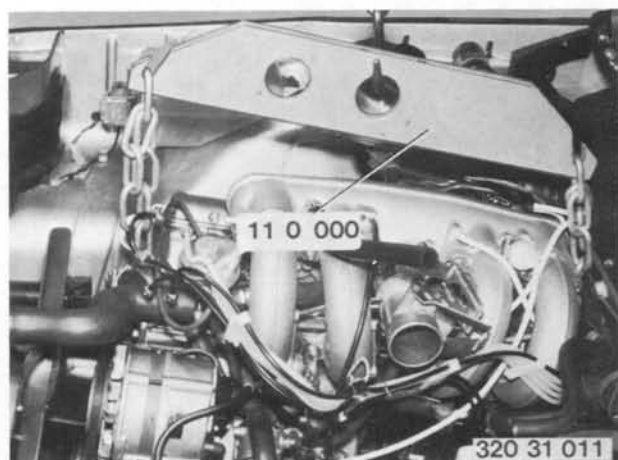

Suspend engine from hoist with Special Tool 11 0 000.

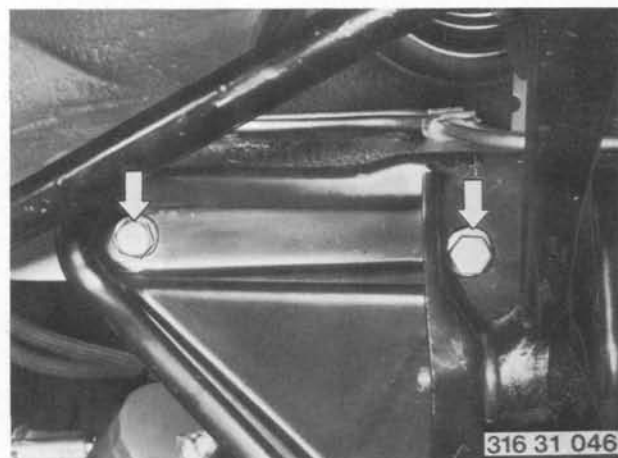

Support front axle support with workshop jack.  
Detach left end of front axle support at frame  
carrier.

Installation Note! Tighten to specified torque<sup>1)</sup>.

1) See Specifications

Detach right end of front axle support at frame carrier.

Installation Note! Tighten to specified torque<sup>1)</sup>.



Unscrew nut and remove bolt.  
Lower front axle support on workshop jack slowly and push universal joint off of steering.

Installation Note! Replace self-locking nuts.  
Make sure that bolt is located in locking groove of steering shaft.

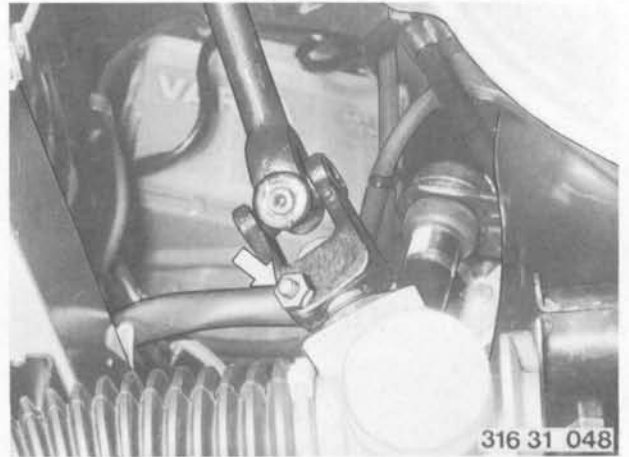

Installation Note! Turn steering wheel until wheels point straight ahead.

Mark (1) on dust seal must be located between marks (2) on housing.

Mount steering spindle on steering in this position.

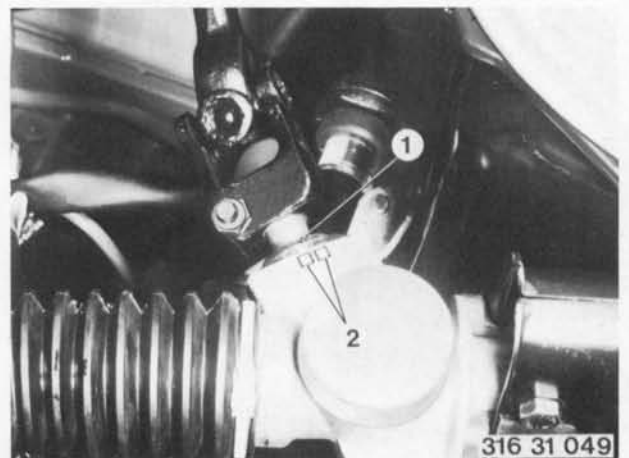

1) See Specifications



31 11 001 REPLACING FRONT AXLE SUPPORT

Remove and install stabilizer - 31 35 000.  
Detach right control arm at front axle support.

Installation Note! Tighten to specified torque<sup>1)</sup>.  
Insert bolt from back to front.  
Replace self-locking nuts.

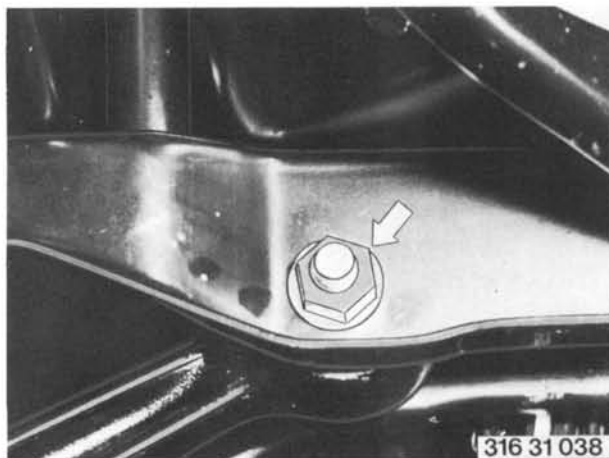

Detach rack-and-pinion steering at front axle support.

Installation Note! Tighten to specified torque<sup>1)</sup>.  
Replace self-locking nuts.



Detach left engine mount (1) and engine damper (2) at front axle support.

Installation Note! Tighten to specified torque<sup>1)</sup>.  
Replace self-locking nuts.  
Make sure that shoulder (3) of engine mount engages in opening provided.

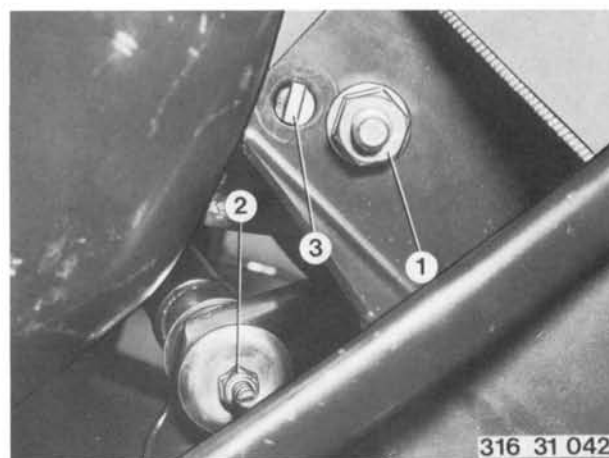

Detach right engine mount (1).

Installation Note! Tighten to specified torque<sup>1)</sup>.  
Make sure that shoulder (2) of engine mount engages in opening provided.

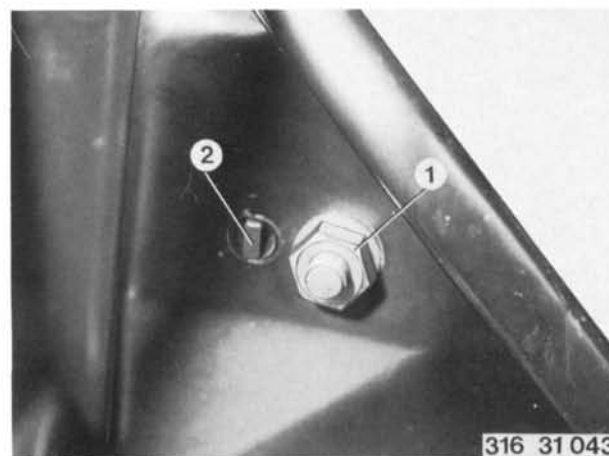

1) See Specifications



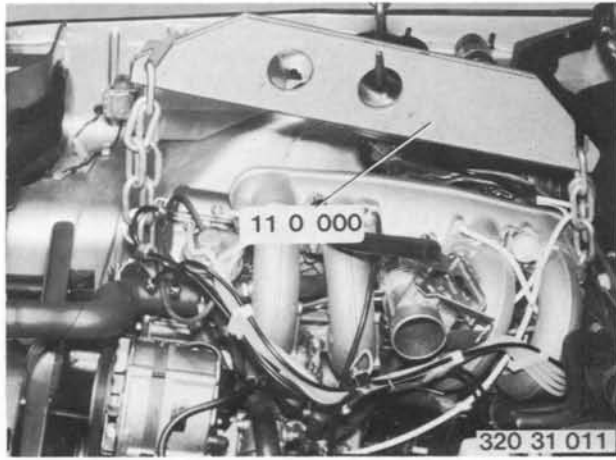

Suspend engine from hoist with Special Tool 11 0 000.

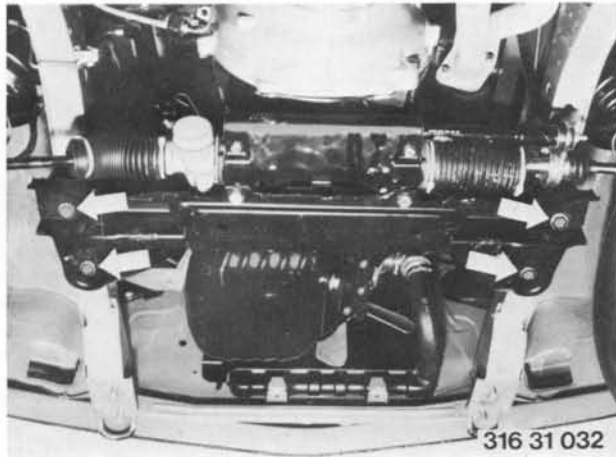

Detach left and right ends of front axle support at frame carrier.

Installation Note! Tighten to specified torque <sup>1)</sup>.

1) See Specifications

31 12 000 REMOVING AND INSTALLING CONTROL ARM

Detach stabilizer at control arm.

Installation Note! Tighten to specified torque<sup>1)</sup>.  
Replace self-locking nuts.

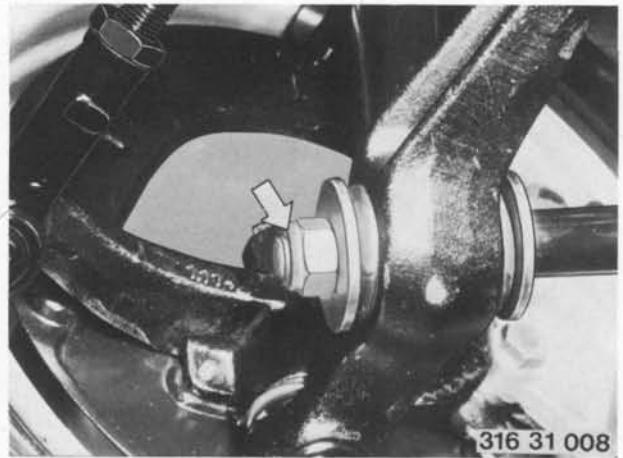

Detach control arm at front axle support.

Installation Note! Tighten to specified torque<sup>1)</sup>.  
Replace self-locking nuts.  
Insert bolt from back to front.

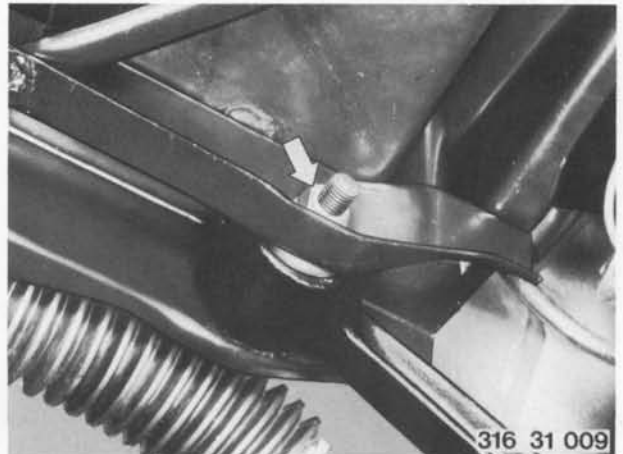

Remove cotter pin and unscrew castle nut.

Installation Note! Tighten to specified torque<sup>1)</sup>.  
Apply coat of 1 : 1 diluted nitro lacquer to castle  
nut and stud.

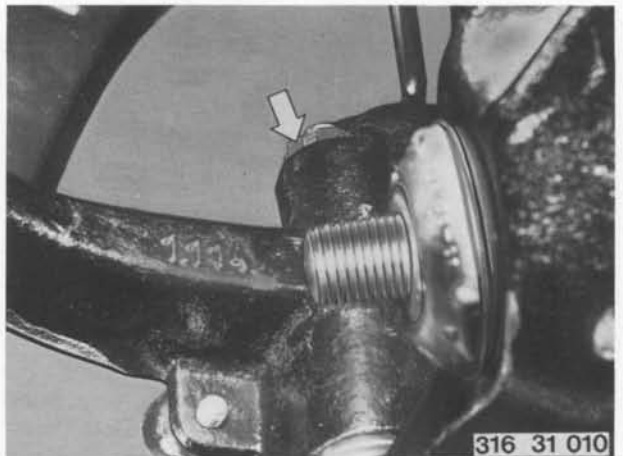

Caution! Special Tool 31 1 100 can be used on left  
and right control arms.  
Loosen socket head cap screws and move clamping bolt  
from left to right or vice versa.

A = For left control arm  
B = For right control arm

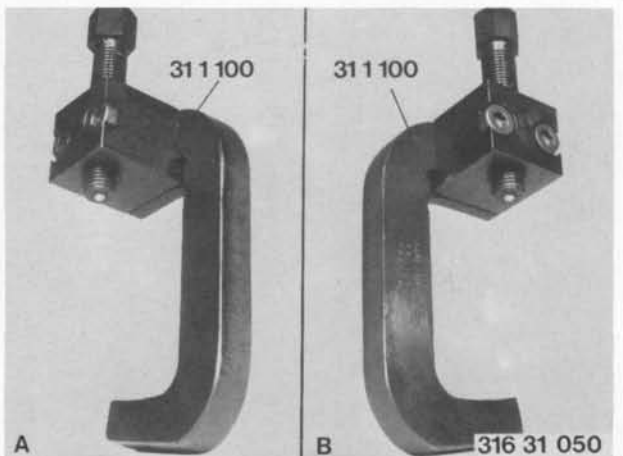

1) See Specifications

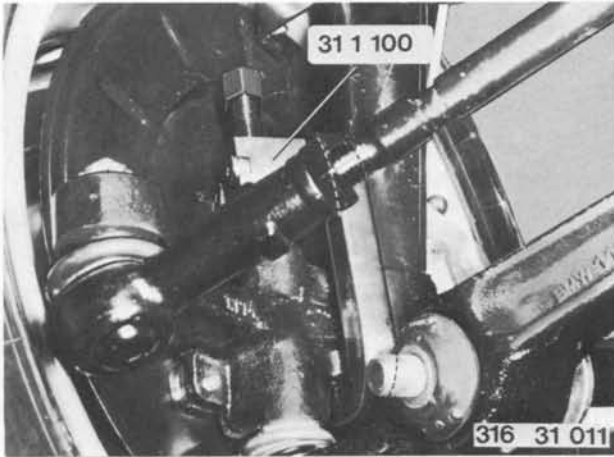

Press control arm off of steering knuckle with Special Tool 31 1 100.

Installation Note! Check joint seal, replace if necessary.

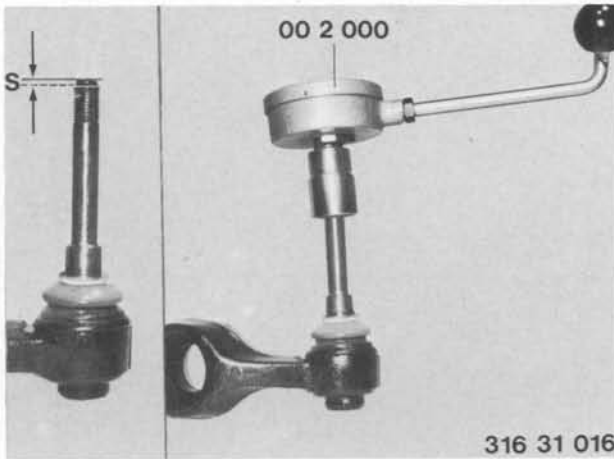

Check friction<sup>1)</sup> with Special Tool 00 2 000. If friction is less than specified value or axial play (S) is more than 1.4 mm (0.055"), replace control arm.

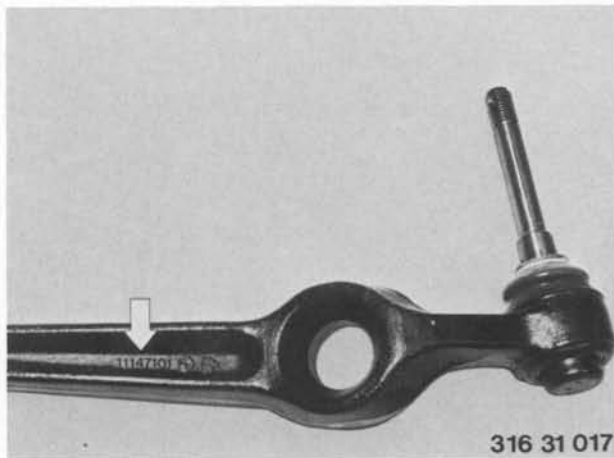

Caution! Note following for friction valve checks.

Control arm, Ehrenreich:	left	1 114 707.1
	right	1 114 708.1
Lemfoerder:	left	1 114 710.1
	right	1 114 711.1

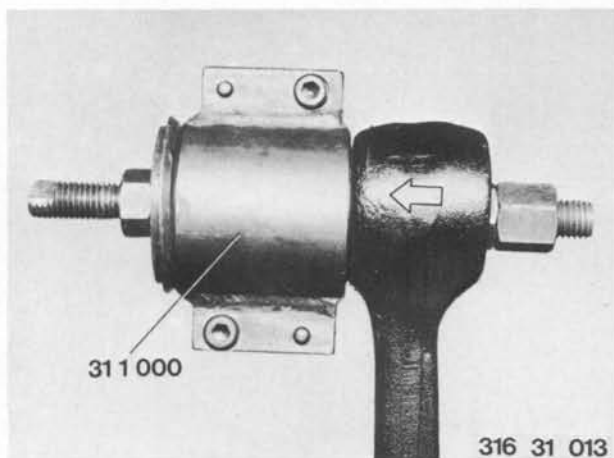

31 12 631 REPLACING CONTROL ARM RUBBER BEARING  
- Control Arm Removed -

Apply Special Tool 31 1 000 and extract rubber bearing.

1) See Specifications

Coat rubber bearing with diluted Cresta, installing oil 11 or low surface tension water, and pull it in with Special Tool 31 1 000.

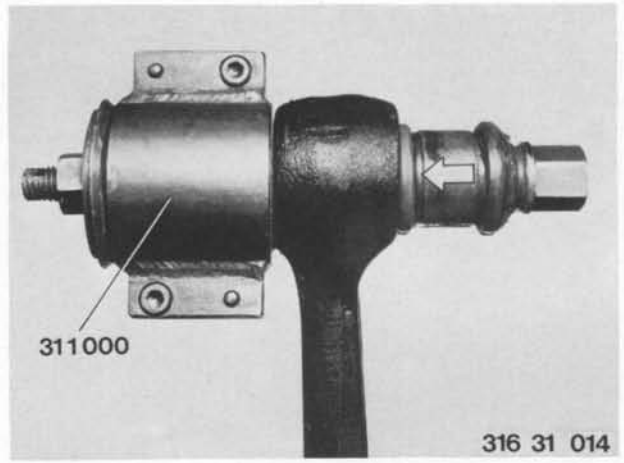

### 31 20 004 ADJUSTING WHEEL BEARING PLAY

Remove and install end cap - 31 21 050.  
Remove cotter pin and unscrew castle nut.  
Add grease to filling, if necessary. 1)

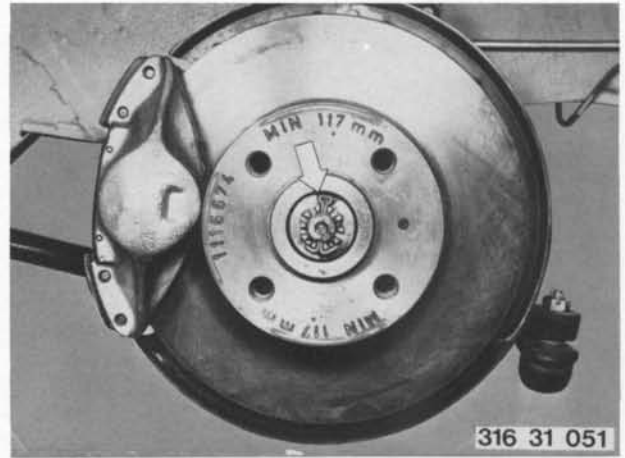

Tighten castle nut to 30 ... 33 Nm / 3.0 ... 3.3 mkp (22 ... 24 ft. lbs.) while turning wheel hub continuously. This will align bearing tapered rollers and inner races. At the same time any grease causing play will be pressed away. Screw on bearing cover at least another 2 turns after tightening. Do not loosen or tighten the castle nut when screwing on bearing cover.

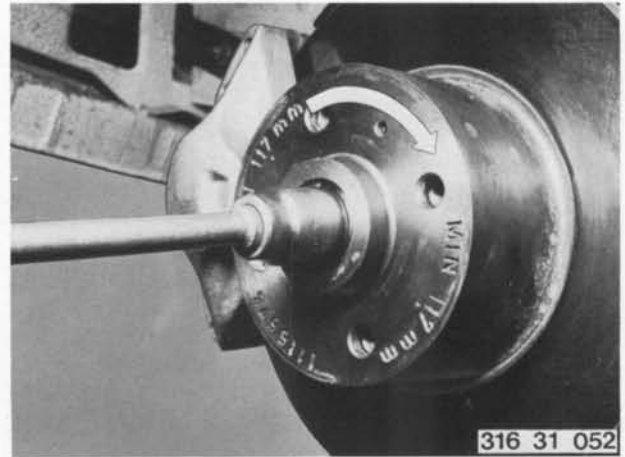

Loosen castle nut until bearing has axial play, whereby the hub must turn again. Tighten castle nut maximum 3 Nm / 0.3 mkp (2 ft. lbs.) and then turn back to nearest hole, in which the cotter pin is inserted.

#### Checking Axial Bearing Play

Disc with lug (1) must move quickly and without any noticeable resistance.

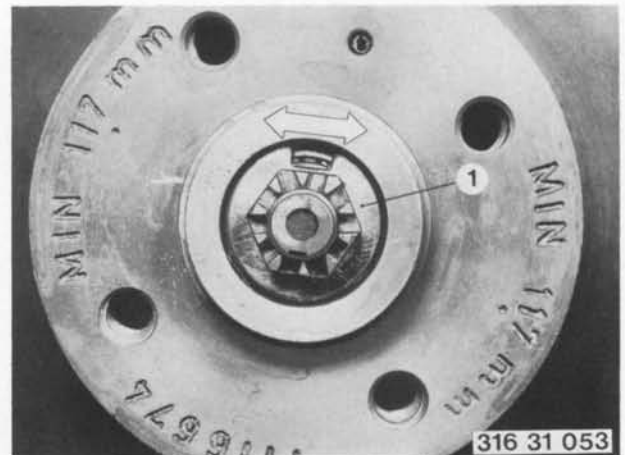

1) See Specifications  
6.76

Wheel Bearing Layout Drawing

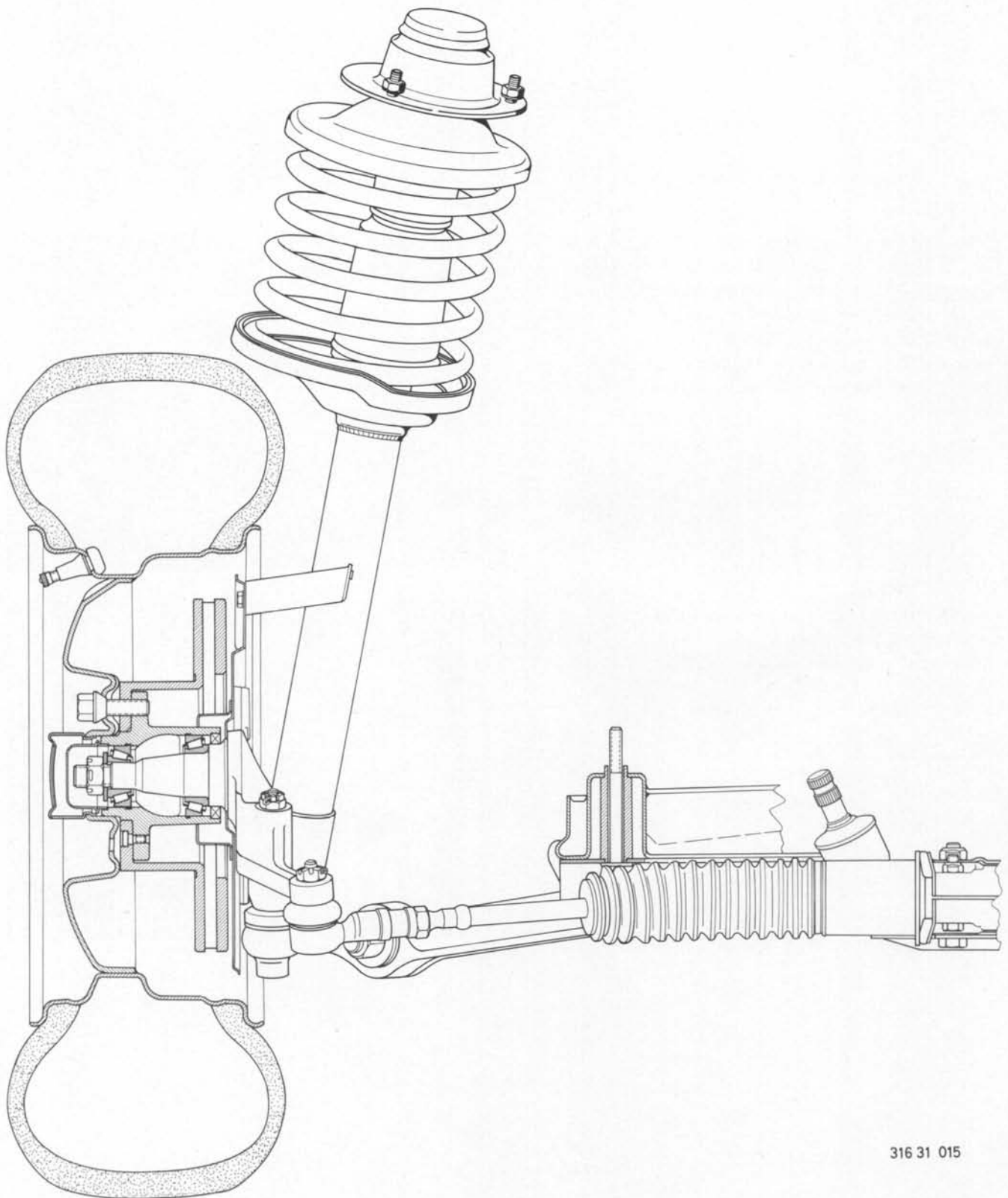

316 31 015



### 31 21 009 CHECKING WHEEL HUB LATERAL RUNOUT

This requires that wheel bearing play is correct.  
Remove and install brake disc - 34 11 200.  
Mount dial gage holder 00 2 500 on spring strut.  
Measure lateral runout 1) on outer most diameter  
of brake disc bearing surface with a dial gage.

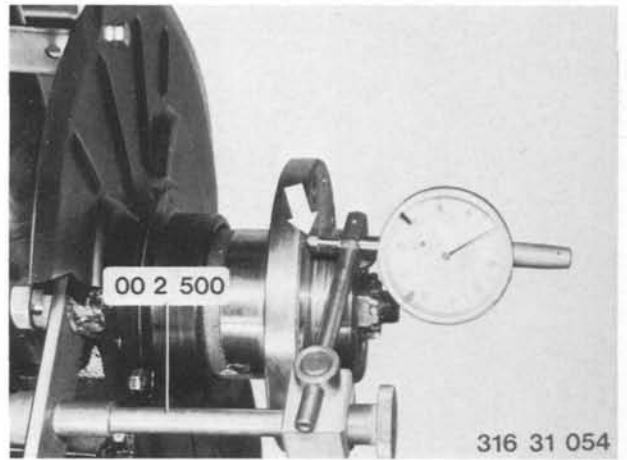

### 31 21 050 REMOVING AND INSTALLING END CAP

Remove and install front wheel - 36 10 300.  
Pry off end cap with Special Tool 31 2 000.

Installation Note! Check grease filling<sup>1)</sup> in end cap,  
replace if necessary.

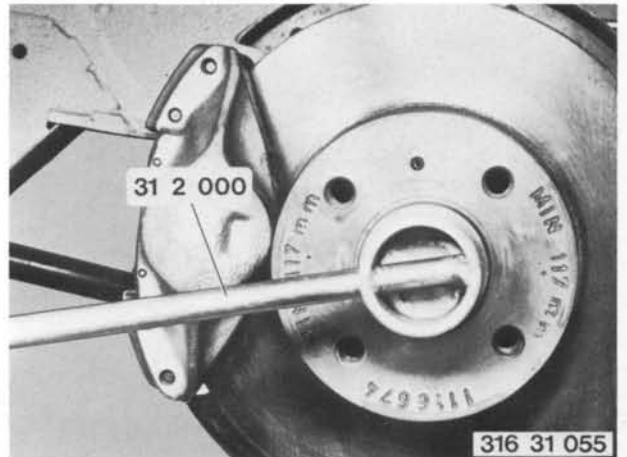

### 31 21 100 REMOVING AND INSTALLING WHEEL HUB

Remove and install end cap - 31 21 050.  
Detach bracket on coil spring/shock absorber strut.

Installation Note! Insert bracket in lock.  
Tighten to specified torque. 1)

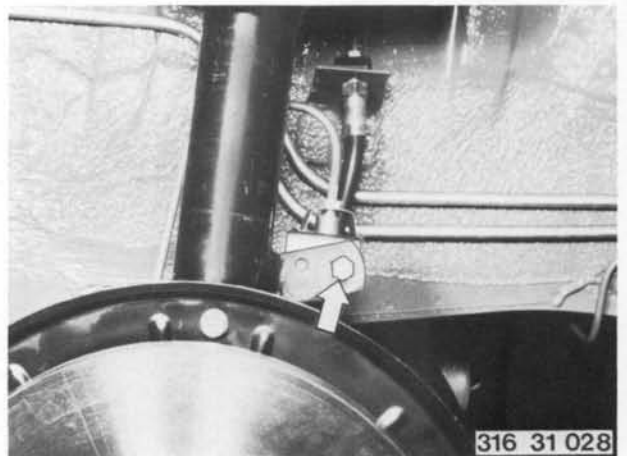

Detach caliper and suspend it from wire.  
Brake line remains connected.

Installation Note! Tighten to specified torque<sup>1)</sup>.

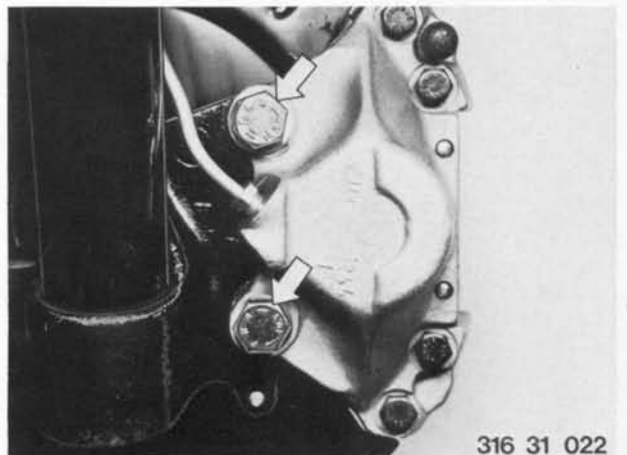

1) See Specifications



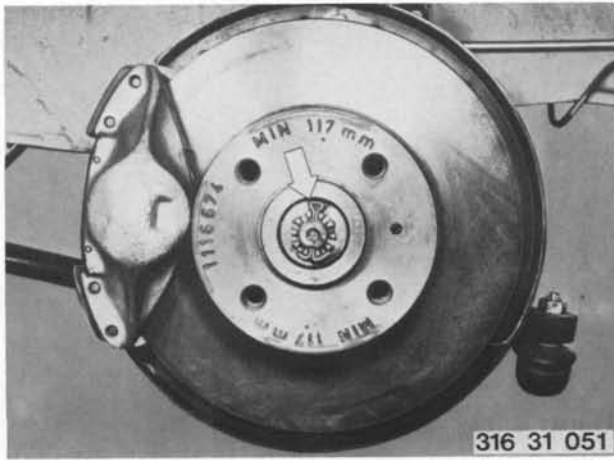

316 31 051

Remove cotter pin and unscrew castle nut.  
Remove lugged disc, brake disc and wheel hub.

Installation Note! Replace grease filling<sup>1)</sup> of wheel hub.

Adjust wheel bearing play - 31 20 004.

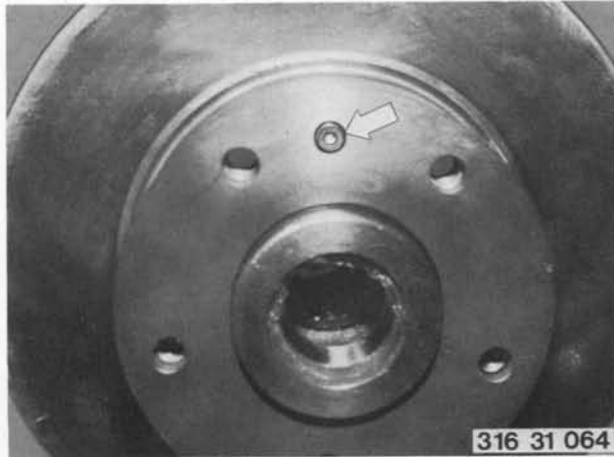

316 31 064

31 21 561 REPLACING WHEEL HUB

- Wheel Hub Removed -

Unscrew socket head cap screw.  
Take brake disc off of wheel hub.

Installation Note! Tighten to specified torque<sup>1)</sup>.  
Replace taper roller bearings and shaft seal.

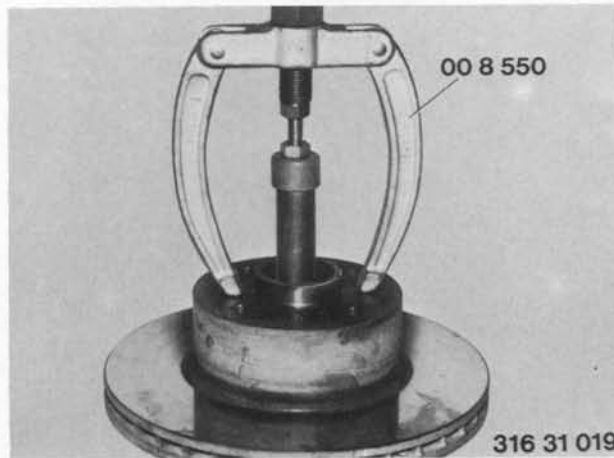

316 31 019

31 21 621 REPLACING TAPER ROLLER BEARINGS AND SHAFT SEAL

- Wheel Hub Removed -

Caution! Use repair kit.

Lift out shaft seal.

Remove taper roller bearings.

Extract bearing outer races with Special Tool  
00 8 550

o r

drive out bearing outer races through openings in wheel hub.

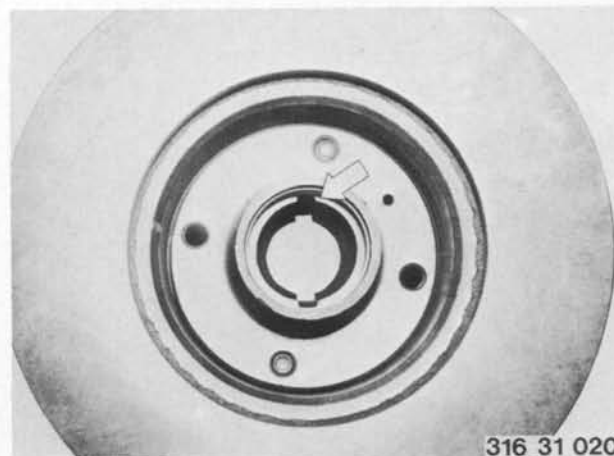

316 31 020

1) See Specifications

Installation Note! Sequence:

- 1 = wheel bearing outer race
- 2 = wheel bearing inner race
- 3 = wheel bearing outer race
- 4 = wheel bearing inner race
- 5 = shaft seal

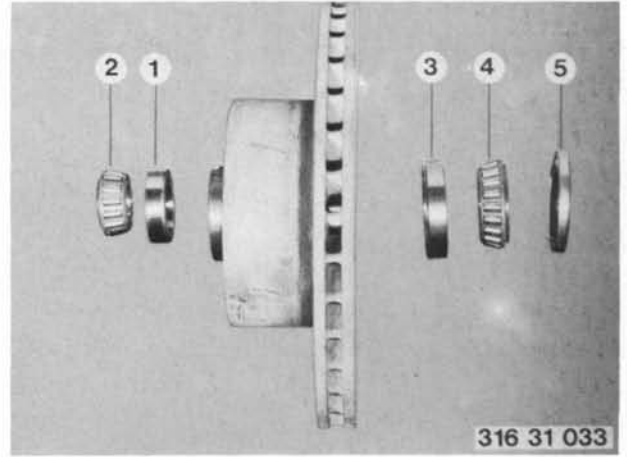

Replace grease filling<sup>1)</sup> of wheel hub.  
Press on bearing outer races up to stop with an appropriate sleeve.  
Fill shaft seal with graphite grease and press on until flush.  
Even if only one bearing is shot, always replace both bearings.

Installation Note! Adjust wheel bearing play - 31 20 004.

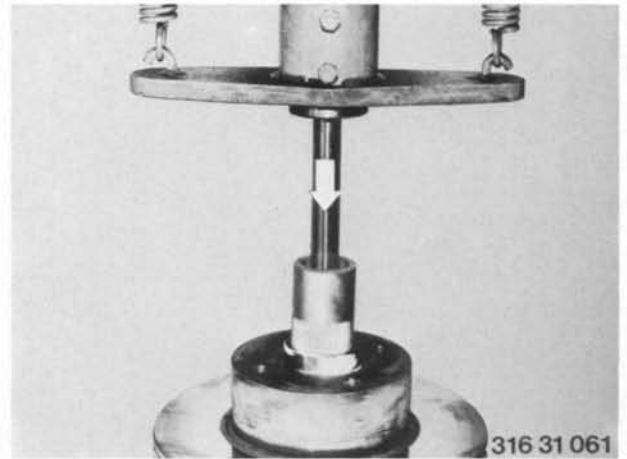

1) See Specifications

31 31 000 REMOVING AND INSTALLING COIL SPRING/  
SHOCK ABSORBER ASSEMBLY

Remove and install front wheel - 36 10 300.  
Detach bracket at coil spring/shock absorber strut.  
Installation Note! Tighten to specified torque<sup>1)</sup>.  
Insert bracket in lock.

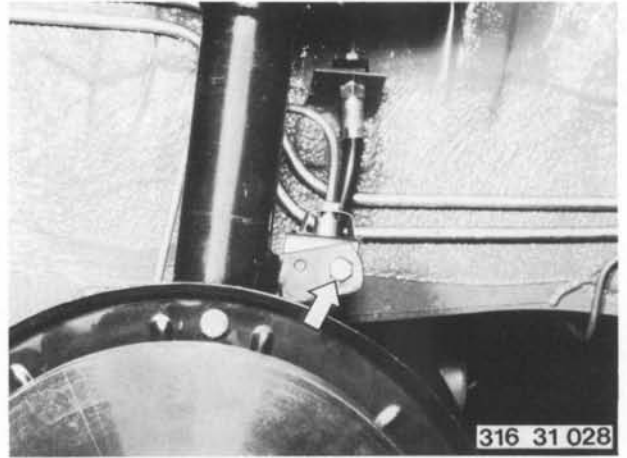

Detach caliper and suspend it from wire.  
Caution! Brake line remains connected.  
Installation Note! Tighten to specified torque<sup>1)</sup>.



Remove cotter pin and unscrew castle nut.  
Press tie rod off of steering knuckle with Special  
Tool 32 2 050.  
Installation Note! Tighten to specified torque<sup>1)</sup>.

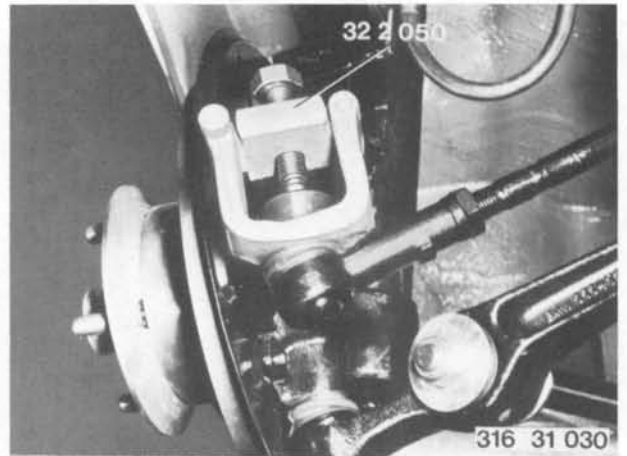

Caution! Special Tool 31 1 100 can be used on left  
and right control arms.  
Unscrew socket head cap screws and move clamping  
screw from left to right or vice versa.

A = For left control arm  
B = For right control arm

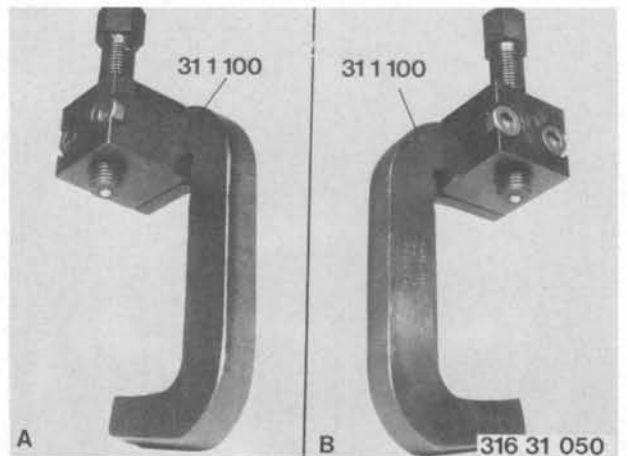

1) See Specifications

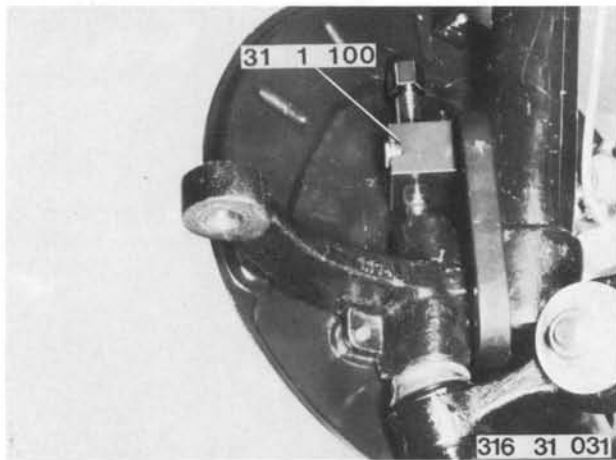

Remove cotter pin and unscrew castle nut.  
Press control arm off of steering knuckle with  
Special Tool 31 1 100.

Installation Note! Tighten to specified torque<sup>1)</sup>.  
Check joint seal, replace if necessary.  
Apply coat of diluted (1 : 1) nitro lacquer to  
castle nut and stud.

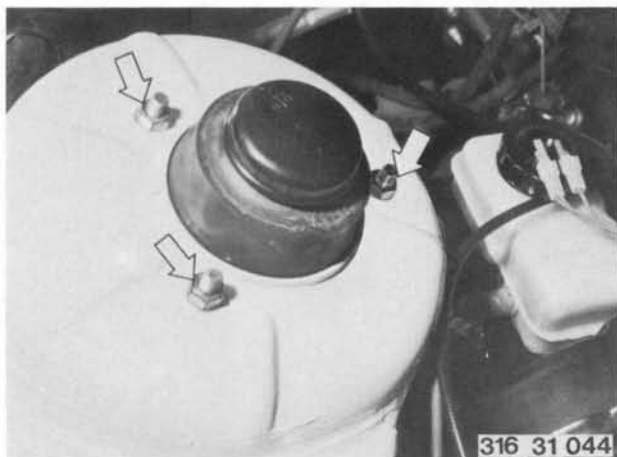

Detach coil spring/shock absorber strut at wheel-  
house.

Installation Note! Tighten to specified torque<sup>1)</sup>.

31 31 031 REPLACING COIL SPRING/SHOCK ABSORBER  
ASSEMBLY

Remove and install coil spring - 31 33 100.  
Transfer guard - 34 11 250.

1) See Specifications

## 31 32 001 REPLACING SHOCK ABSORBER

**Caution!** When replacing just one shock absorber, install one of same make <sup>1)</sup>.

To determine whether a shock absorber needs to be replaced, check an installed shock absorber with a shock absorber tester or similar device or a removed shock absorber in a shock absorber test bench <sup>1)</sup>. Generally it is known that shock absorbers will have about 50 % less damping effect than originally after going through two sets of tires. At this time the shock absorbers should be checked and both shock absorbers of either axle replaced together, if applicable.

Note information in Specifications for conversion to difficult operating conditions.

Remove and install coil spring - 31 33 100.  
Pull auxiliary spring with outer tube off of piston rod.  
Unscrew threaded ring with Special Tool 31 3 150.  
Installation Note! Tighten to specified torque <sup>1)</sup>.

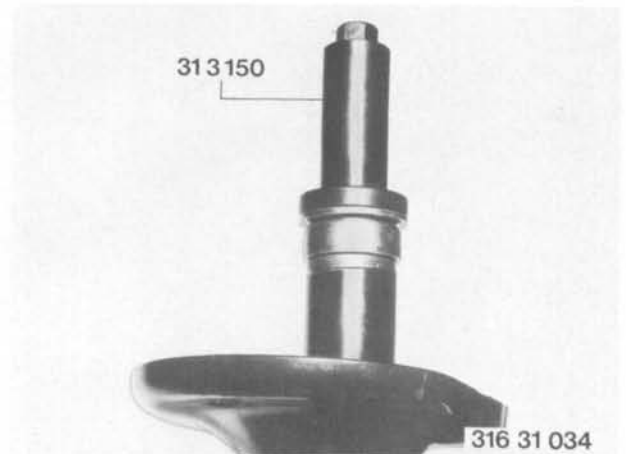

Pull out shock absorber (1).

Installation Note! Take old oil out of strut pipe (2).  
Add engine oil <sup>1)</sup> before installing new shock absorber.

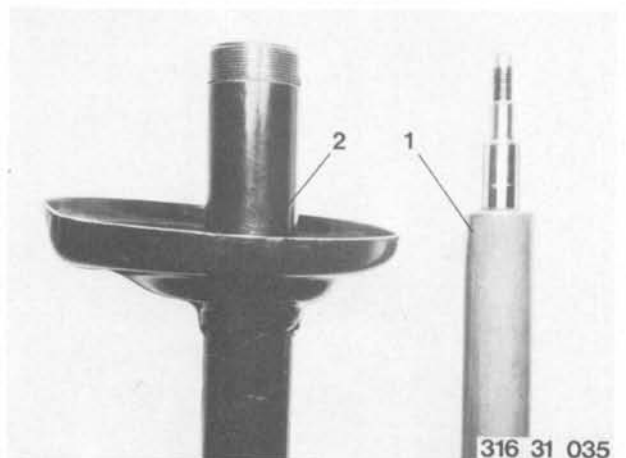

1) See Specifications

31 33 000 REMOVING AND INSTALLING SPRING STRUT  
SUPPORT BEARING

Remove and install coil spring/shock absorber strut  
- 31 31 000.  
Compress coil spring with Special Tool 31 3 110.

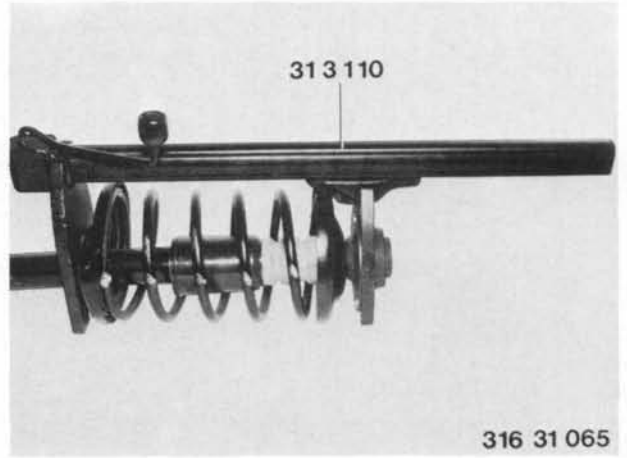

Lift off end cap.  
Unscrew self-locking nut (1).  
Counterhold piston rod (2).  
Release coil spring and remove spring strut support  
bearing.

Installation Note! Tighten to specified torque<sup>1)</sup>.  
Replace self-locking nut.

Caution! Only replace a complete spring strut  
support bearing.

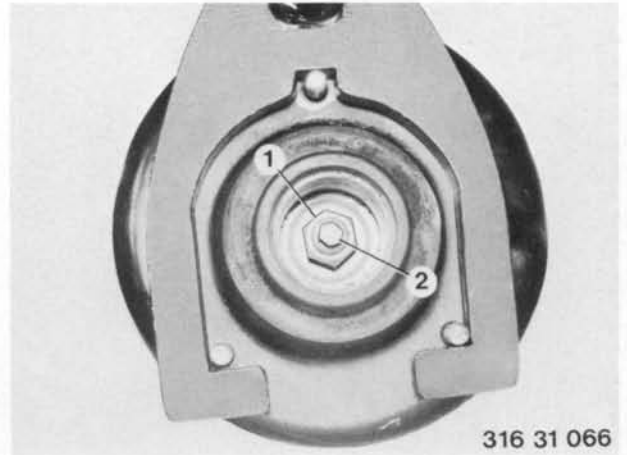

Installation Note! Screw Special Tool 31 3 111 on  
piston rod to facilitate installation of piston rod  
on spring strut support bearing.  
Pull out piston rod all the way.  
Align coil spring before compressing.  
Compress support bearing and coil spring with Speci-  
al Tool 31 3 110.

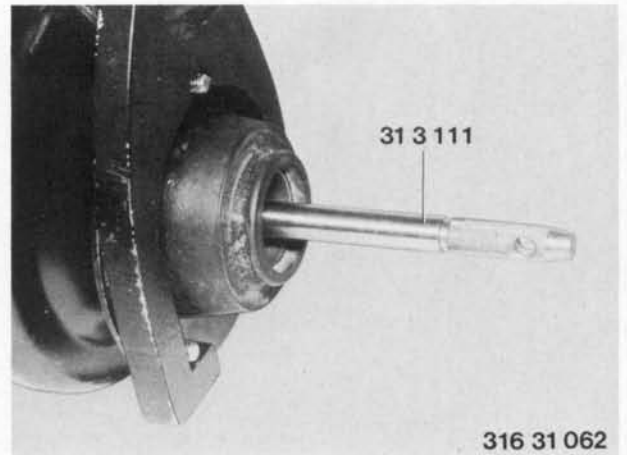

Sequence of Installation

- 1 = Large diameter washer
  - 2 = Sealing washer
  - 3 = Support bearing
  - 4 = Concave washer
  - 5 = Self-locking nut
- Inside concave of sealing washer (2) and washer (4)  
faces support bearing.

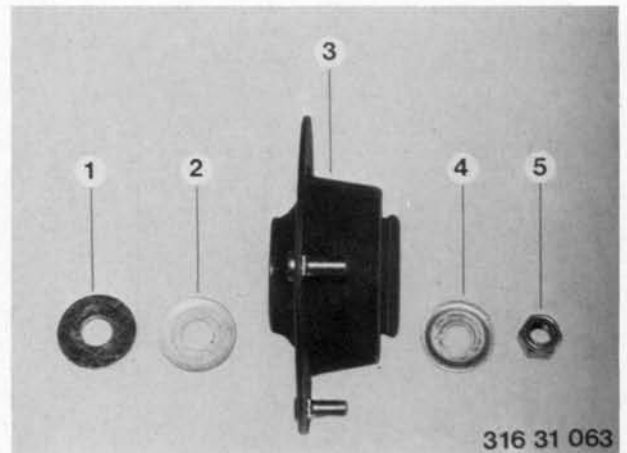

1) See Specifications



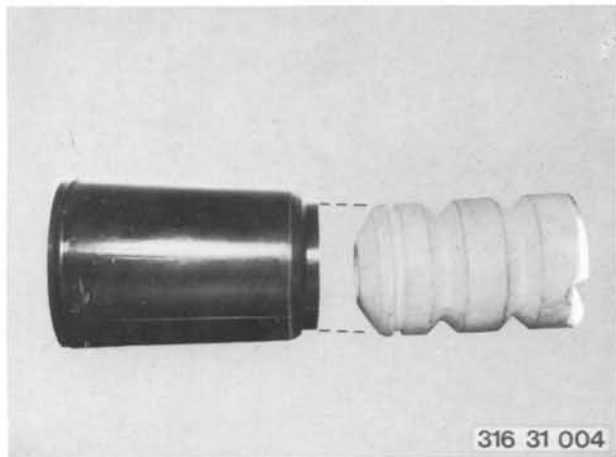

### 31 33 051 REPLACING OUTER TUBE

Remove and install spring strut support bearing - 31 33 000.  
Scrape auxiliary spring with outer tube off of piston rod.  
Pull outer tube off of auxiliary spring.

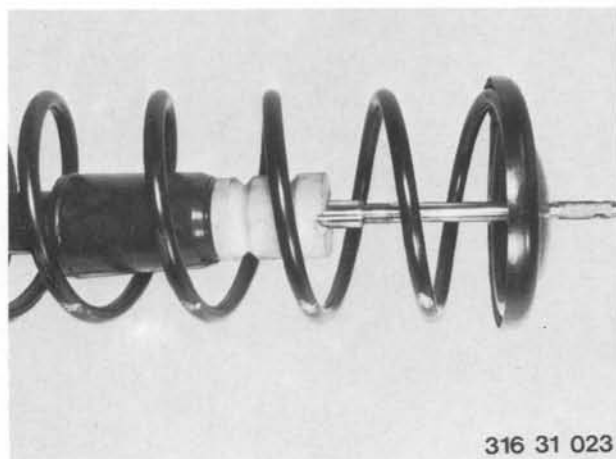

### 31 33 100 REMOVING AND INSTALLING COIL SPRING

Remove and install spring strut support bearing - 31 33 000.  
Remove upper spring retainer with liner and coil spring.

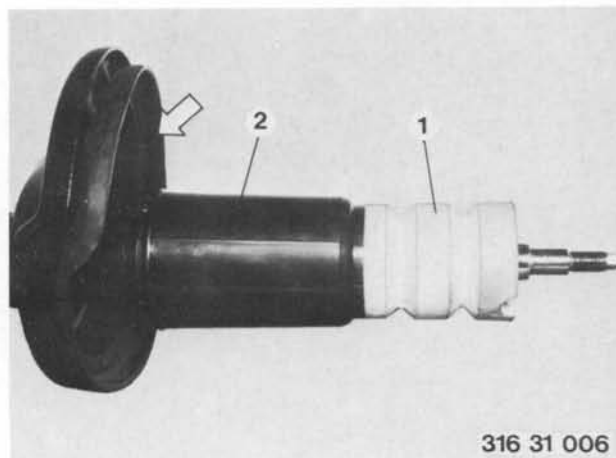

Installation Note! Check damper rings for coil spring, auxiliary spring (1) and outer tube (2), replace if necessary.  
The coil spring ends must rest on shoulders in upper and lower spring retainers.

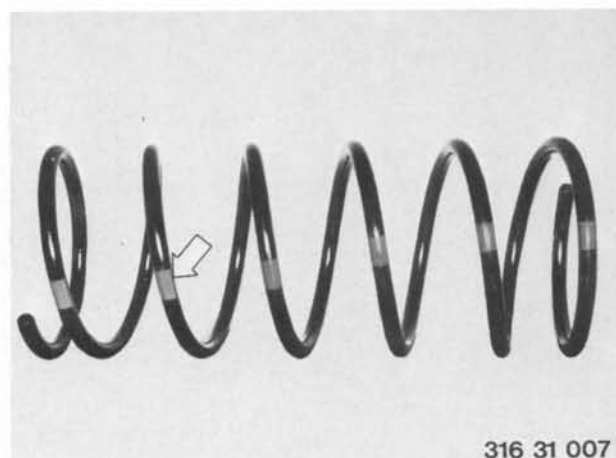

### 31 33 101 REPLACING COIL SPRING

Remove and install coil spring - 31 33 100.

Caution! Replace coil springs in pairs only.  
Note length of spring (1), color code (1) and diameter (1).

Note information in Specifications for conversion to difficult operating conditions.

1) See Specifications



31 35 000 REMOVING AND INSTALLING STABILIZER

Unscrew left and right self-locking nuts on control arm.

Installation Note! Tighten to specified torque<sup>1)</sup>.  
Check rubber bearing, replace if necessary.  
Replace self-locking nuts.

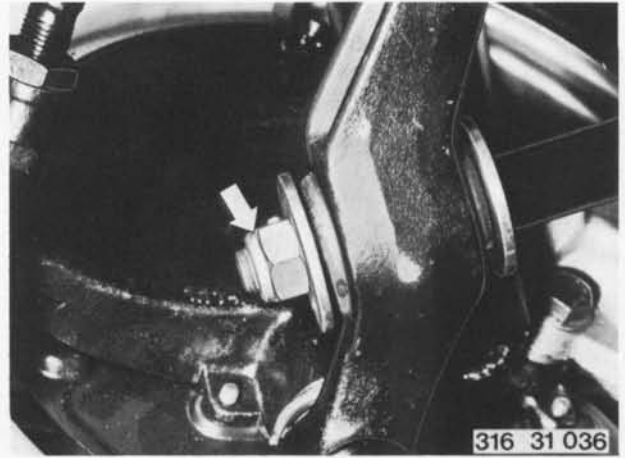

Detach holder and rubber bearing.

Installation Note! Tighten to specified torque<sup>1)</sup>.  
Check rubber bearing, replace if necessary.  
Replace self-locking nuts.



Detach control arm at one end of front axle support.

Installation Note! Replace self-locking nuts.  
Tighten to specified torque. 1)

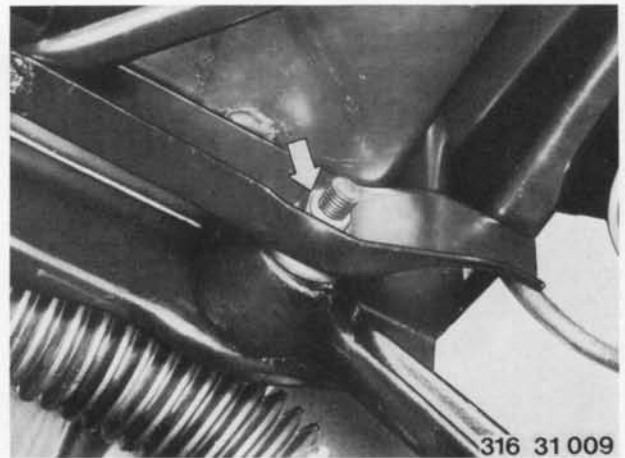

1) See Specifications