

32 Steering and Axle Alignment

	Page
Specifications	32- 0/3
32 00 024 Optical Front Axle Alignment	00/1
054 Optical Rear Axle Alignment	00/2
32 10 004 Adjusting Steering Gear	10/1
32 11 000 Removing and Installing Steering Gear Assembly	11/1
001 Replacing Steering Gear	11/2
003 Disassembling and Assembling Steering Gear	11/3
32 21 231 Replacing Left Tie Rod	21/1
241 Replacing Right Tie Rod	21/1
32 31 000 Removing and Installing Upper Steering Column Casing	31/1
001 Replacing Upper Steering Column Casing	31/2
020 Removing and Installing Lower Steering Column Casing	31/2
051 Replacing Coupling	31/2
070 Removing and Installing Lower Steering Spindle	31/2
080 Replacing Steering Spindle	31/3
090 Removing and Installing Steering Column	31/4
131 Replacing Turn Signal Switch Cancelling Cam	31/5
151 Replacing Upper Steering Spindle Bearing	31/5
161 Replacing Lower Steering Spindle Bearing	31/6
211 Replacing Lower Steering Spindle Universal Joint	31/7
32 32 000 Removing and Installing Steering Lock	32/1
050 Removing and Installing Steering Lock Cylinder	32/1
32 33 000 Removing and Installing Steering Wheel	33/1
041 Replacing Steering Wheel Horn Button	33/1
551 Replacing Carbon Brush Horn Contact	33/1

Model

320 i

320 i A

Normal car load position (for adjustments)

2 x 68 kg (150 lbs.) on front seats, 1 x 68 kg (150 lbs.) on rear seats, 21 kg (46 lbs.) in trunk and full fuel tank

<u>Front Axle</u>			
<u>1)</u> Toe	mm (in.)	1.5^{+1} -0.5	$(0.059^{+0.040}$ $-0.020)$
Camber ¹⁾	0	$0^{\circ} 14'$ $+9'$ $-4'$	
Toe difference angle ¹⁾ at 20° wheel lock on inside wheel	0	$0^{\circ} \pm 30'$	
King pin inclination ¹⁾	0	$0^{\circ} 45' \pm 30'$	
<u>1)</u> Caster	0	$10^{\circ} 54' \pm 30'$	
Max. caster difference between wheels	0	$8^{\circ} 20' \pm 30'$	
Max. wheel lock	0	$0^{\circ} 30'$	
Inside wheel	0	40.4	
Outside wheel	0	35.5	
Smallest track circle	m (ft.)	9.40 (30.8)	
Left	m (ft.)	9.60 (31.5)	
Right	m (ft.)	10.20 (33.5)	
Smallest turning circle	m (ft.)	10.40 (34.1)	
Left			
Right			
<u>Rear Axle</u>			
<u>1)</u> Toe	mm (in.)	1 ± 1	(0.040 ± 0.040)
	0	$0^{\circ} 10' \pm 10'$	

1) In normal car load position (see above).

Model	320 i	320 i A
<u>Continuation of Rear Axle</u>		
Toe without load	mm (in.)	0.4 ± 1 (0.016 \pm 0.040)
	0	$0^{\circ} 4' \pm 10'$
Camber ¹⁾	0	$- 2^{\circ} \pm 30'$ (negative)
<u>Steering</u>		
Design		rack and pinion on resilient rubber mounts
<u>Steering Gear</u>		
Design		ZF rack and pinion steering gear
Ratio		$1 \cong 38$ mm (1.496") on steering rack
Steering wheel turns \cong stroke		$4.05 \cong 154$ mm (6.063") on steering rack (without tie rods)
Total steering wheel turns \cong total stroke		153 mm (6.024") - left: 77 ± 0.4 mm (3.031 \pm 0.016"), right: 76 ± 0.4 mm (2.992 \pm 0.016") (with tie rod/with steering damper)
Turning torque (friction moment)		
- <u>Steering Gear Removed</u> - Within 360° = 0.5 steering wheel turns per side from center position	Ncm/kpcm(in lbs) at rpm	90 ... 130 / 9.0 ... 13.0 (7.8 ... 11.2) 15
Beyond this range	Ncm/kpcm(in lbs) at rpm	max. 200 / 20 (17.4) 15
Max. pressure pad axial play after adjusting pressure pad and at specified turning torque	mm (in.)	0.1 (0.004)
Rack diameter	mm (in.)	24 (0.945)

1) In normal car load position (see Page 32-0/3).

2) Mean value of turning torque; max. deviation from mean value is ± 15 Ncm / 1.5 kpcm (1.3 in. lbs.)

Model 320 i 320 i A

Continuation of Steering Gear

No. of pinion teeth (bevelled)	6
Distance betw. face ball axial joints (steering gear with steering damper)	593 (23.346")
Pinion spline (steering column connection)	1 x 54 ZGN 715 (cylindrical)
Zero setting (straight)	mark on steering box and dust seal (pinion)
Type of steering gear grease	Calypsol D 4024-OK
Amount of grease	20 ... 30
Max. steered axle load	7500 / 764 (1684)

Steering Damper

Design	Boge single - tube hydraulic damper
Color code	none (light blue ring of paint ¹⁾)
Stroke	≥ 156 (6.142)
Steering damper test	100 (100 ¹⁾) 100
Speed	100 (100 ¹⁾) 100
Stroke	25 (.984)/10 (.394 ¹⁾) 25 (.984)/25 (.984 ¹⁾) 50 (1.968)
Push/pull	210 (270 ... 330 ¹⁾) 430 (500 ... 600 ¹⁾) 590
	21 (27.4 ... 33.6 ¹⁾) 43.8 (51 ... 61 ¹⁾) 60
	46 (60 ... 74 ¹⁾) 96.5 (112 ... 134 ¹⁾) 132
	100 (100 ¹⁾) 100
	75 (2.953)
	100 (3.937)
	810
	82.5
	182

Tie Rods

2 side-mounted tie rods attached to outer ends of central steering rack

Steering Column

safety steering column with split steering spindle, 2 universal joints and 1 rubber coupling

1) California Version.

Model

320 i

320 i A

Steering Spindle

Upper steering spindle length	mm (in.)	737 (29.016)
Lower steering spindle length (from universal joint centerline to universal joint centerline)	mm (in.)	229 (9.016)
Steering wheel nut threads		M 14 x 1.5

Steering Wheel

Steering wheel diameter	mm (in.)	380 (14.961)
Max. deviation of steering wheel spoke position from center location (wheels pointing straight ahead)	0	± 1

four-spoke safety steering wheel with four horn buttons and one padded crash pad

Steering Lock

with buzzer warning switch to indicate that ignition key is in lock when door is opened

Torque Specifications in Nm / kpm (ft. lbs.)

Steering wheel to spindle M 14 x 1.5	85 ...	95 / 8.5 ...	9.5 (62 ... 69)	Tie rod axial joint to steering gear rack	70 ...	78 / 7.0 ...	7.8 (51 ... 56)
Universal joint to upper spindle	25 ...	28 / 2.5 ...	2.8 (18 ... 20)	M 14 x 1.5	35 ...	40 / 3.5 ...	4.0 (25 ... 29)
Universal joint to steering gear pinion	25 ...	28 / 2.5 ...	2.8 (18 ... 20)	Tie rod to steering knuckle M 10 x 1	25 ...	28 / 2.5 ...	2.8 (18 ... 20)
Universal joint to coupling or lower steering spindle	20 ...	23 / 2.0 ...	2.3 (15 ... 17)	Bearing plate to steering gear M 8	49 ...	54 / 4.9 ...	5.4 (35 ... 39)
Clamp for casing tube	17 ...	19 / 1.7 ...	1.9 (12 ... 14)	Steering gear to front axle support M 10	60 ...	70 / 6.0 ...	7.0 (44 ... 50)
Large set screw for steering gear/ drive pinion mounting	22 ...	26 / 2.2 ...	2.6 (16 ... 19)	Guide joint to steering knuckle	15 ...	18 / 1.5 ...	1.8 (11 ... 13)
Tie rod to ball joint counter nut M 14	55 ...	65 / 5.5 ...	6.5 (40 ... 47)	Outer steering damper mounting M 8 x 1	15 ...	18 / 1.5 ...	1.8 (11 ... 13)
				Inner steering damper mounting M 8 x 1	15 ...	18 / 1.5 ...	1.8 (11 ... 13)

Accurate axle alignment requires fulfilment of the following points.

1. Good even tire treads.
2. Specified tire pressures.
3. Rims in good condition.
4. Specified wheel bearing play.
5. Car brought to normal load condition¹⁾.

Determine actual values with optical equipment.

Fill in data sheet.¹⁾
 Note specifications.



20° right-hand lock measured on left wheel

20° left-hand lock measured on right wheel

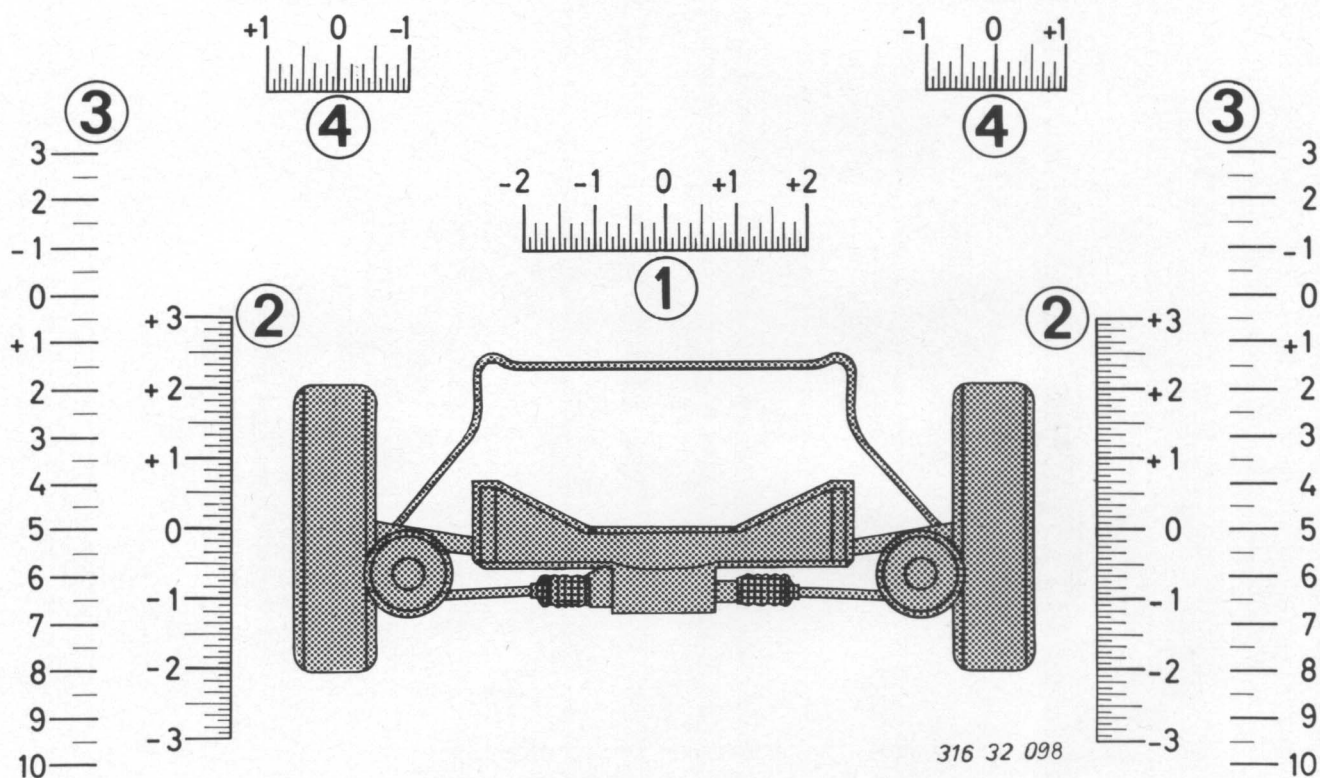

Troubleshooting

1 Track Width Incorrect

- a) Tie rod bent
- b) Steering knuckle bent
- c) Tie rod ball joint worn

2 Camber Deviation

- a) Control arm bent
- b) Spring strut bent
- c) Front axle support bent
- d) Wheelhouse bent
- e) Guide joint worn
- f) Excessive wheel bearing play
- g) Excessive spring deflection
- h) Distortion in frame/floor assembly

3 Caster Deviation

- a) Control arm bent
- b) Spring strut bent
- c) Wheelhouse bent
- d) Distortion in frame/floor assembly

4 Toe Difference Angle Incorrect

- (assuming that camber and caster are correct)
- a) Tie rods non-uniformly adjusted
 - b) Steering knuckle bent

1) See Specifications

32 00 054 OPTICAL REAR AXLE ALIGNMENT

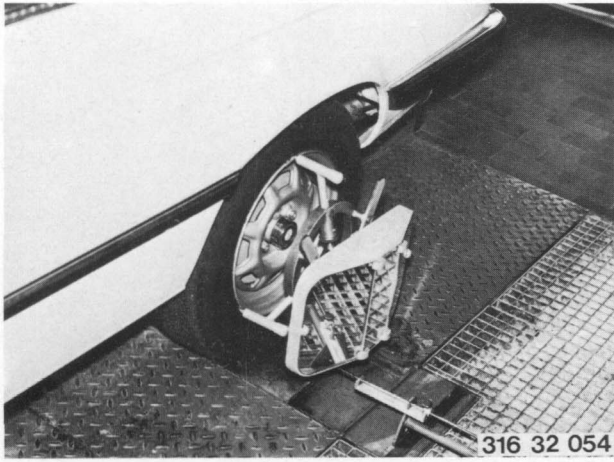

Accurate axle alignment requires fulfilment of the following points.

1. Good even tire treads.
 2. Specified tire pressures.
 3. Rims in good condition.
 4. Specified wheel bearing play.
 5. Car brought to normal load position¹⁾.
- Determine actual values with optical equipment.
Fill in data sheet.¹⁾
Note specifications .



6



6

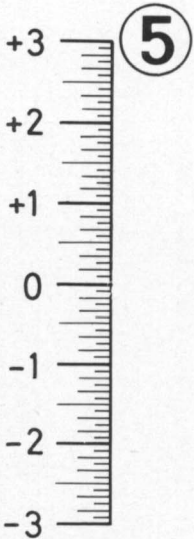

5

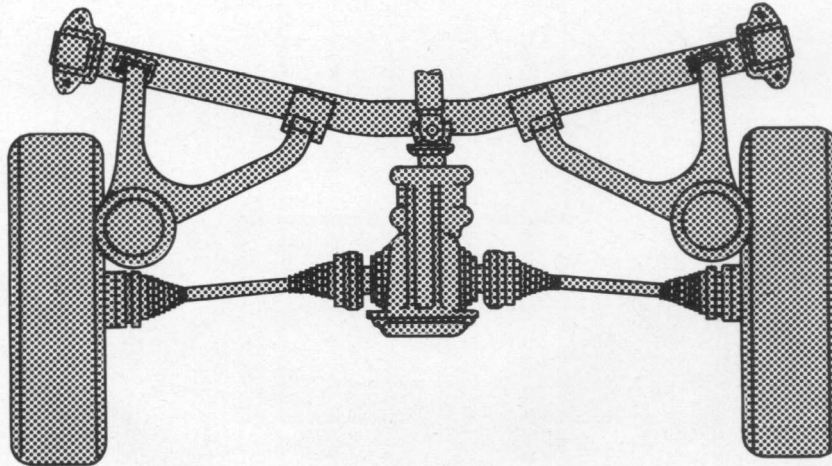

5



7



Troubleshooting

5 Camber Deviation

- a) Rubber mount on rear axle support defective
- b) Rubber mount on rear axle final drive defective
- c) Control arm bushings defective
- d) Rear axle support deformed
- e) Control arms deformed
- f) Distortion in frame/floor assembly

6 Rear Wheel Position Incorrect

- a) Rear axle support shifted laterally
- b) Distortion in frame/floor assembly

7 Track Width Incorrect

- a) Rear axle support deformed
- b) Control arms deformed
- c) Control arm bushings defective
- d) Rubber mount on rear axle support defective
- e) Spring deflection too high

1) See Specifications

32 10 004 ADJUSTING STEERING GEAR

Remove and install steering gear - 32 11 000.
Clamp Special Tool 32 1 100 in a vise and insert steering gear into special tool.

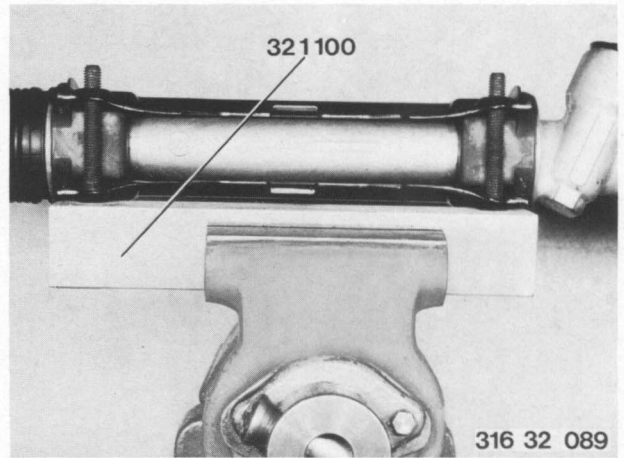

Unscrew nut on steering damper and slide back steering damper.

Installation Note! Tighten to specified torque¹⁾.
Replace self-locking nut.

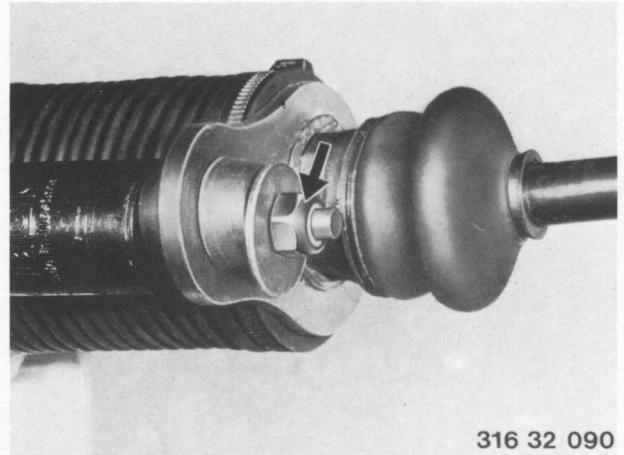

Remove cap and unscrew socket head cap screw by about 12 mm (1/2") (A).

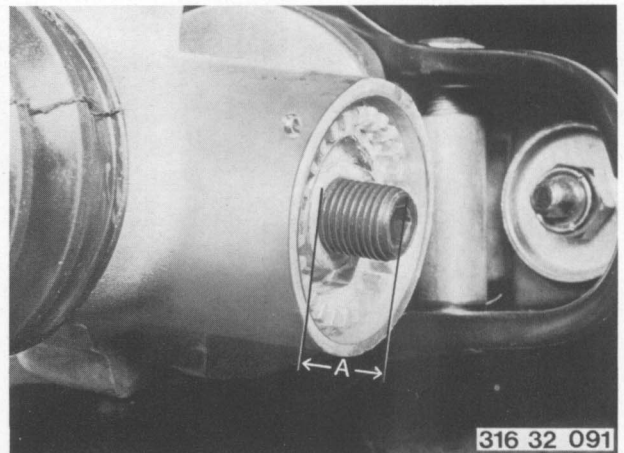

a) Pressure Pad Adjustment

Remove cotter pin.
Tighten set screw with Special Tool 32 1 040 and torque wrench to 6 Nm / 0.6 kpm (4 ft. lbs.).
Loosen set screw by one full castle slot to cotter pin bore.

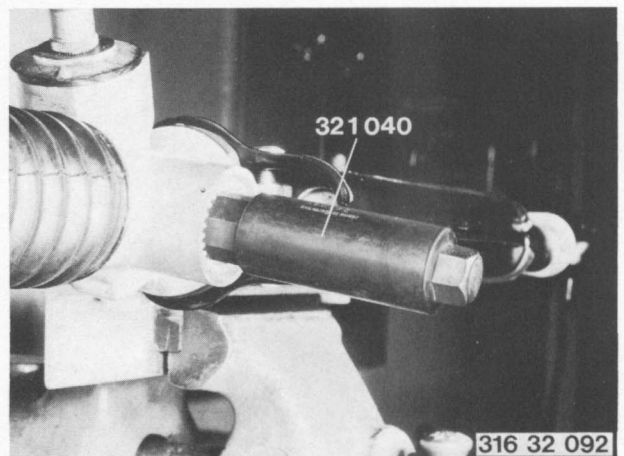

1) See Specifications

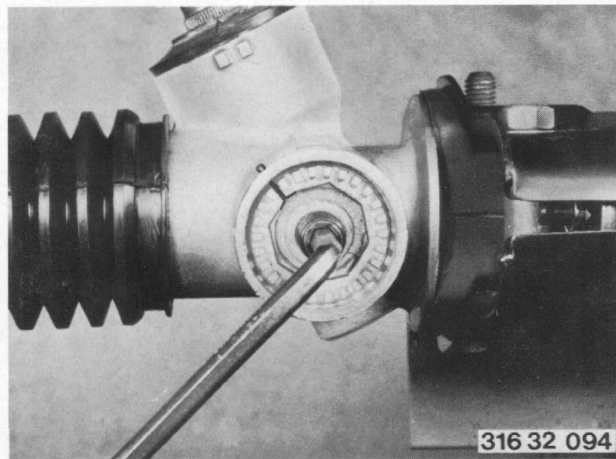
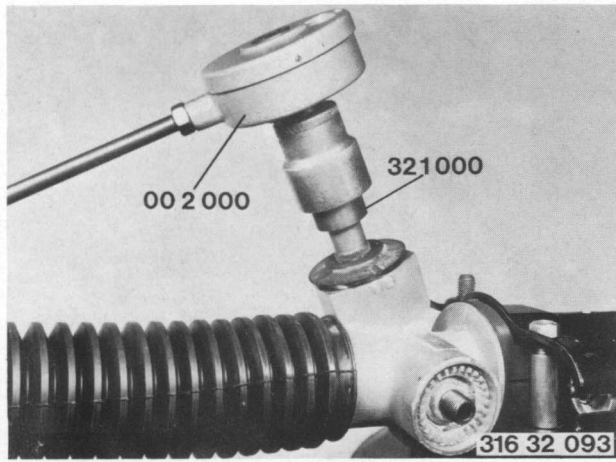

Use Special Tools 32 1 000 and 00 2 000 to move rack to the left and right over the entire stroke and check for sticking and hooking.

If this is the case loosen set screw (9) by one more castle slot and insert cotter pin.

Repeat test. If there is still sticking or hooking, replace rack, drive pinion or, if necessary, the entire steering gear.

Never loosen screw by a further castle slot regardless of circumstances.

b) Turning Torque Adjustment

Move rack to center position. Mount Special Tools 00 2 000 and 32 1 000 on drive pinion. Check turning torque 1). If friction does not correspond with specifications, adjust set screw (11).

Turn to the right = more friction

Turn to the left = less friction

Install cap.

1) See Specifications

32 11 000 REMOVING AND INSTALLING STEERING GEAR ASSEMBLY

Loosen front wheels.
Remove cotter pin and unscrew castle nut.
Press tie rods off of steering knuckles with Special Tool 32 2 050.

Installation Note! Tighten to specified torque¹⁾.
Check joint seal, replace if necessary.

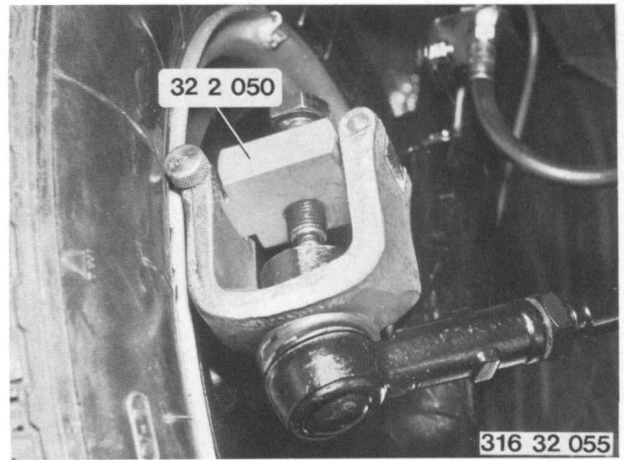

Detach steering at front axle support.

Installation Note! Tighten to specified torque¹⁾.
Replace self-locking nuts.

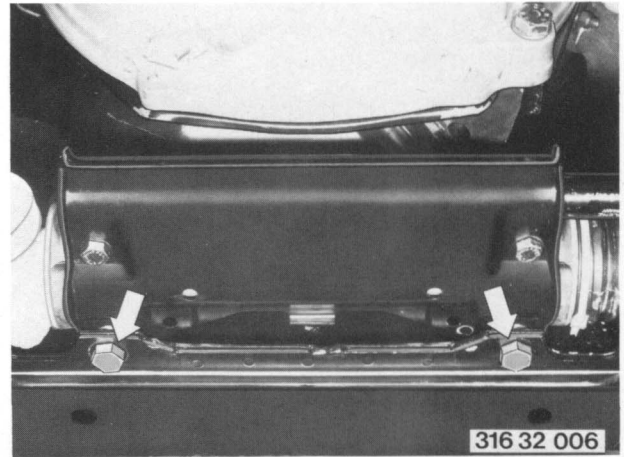

Unscrew nut and remove bolt.
Pull steering gear off of steering spindle.

Installation Note! Tighten to specified torque¹⁾.
Replace self-locking nuts.
Make sure that bolt is in locking groove.

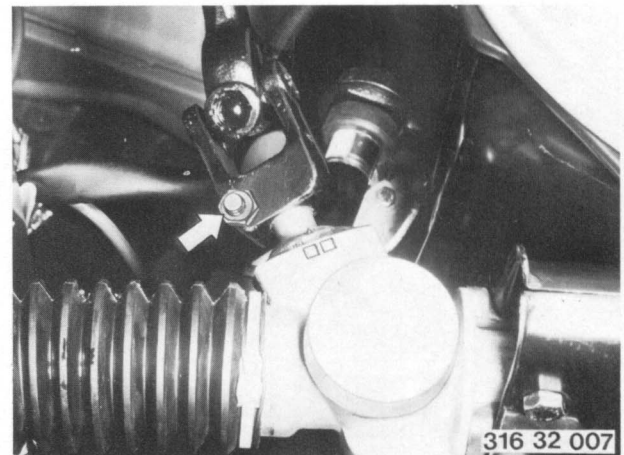

Installation Note! Turn steering wheel until wheels point straight ahead.
Mark (1) on dust seal must be between marks (2) on steering gear box.

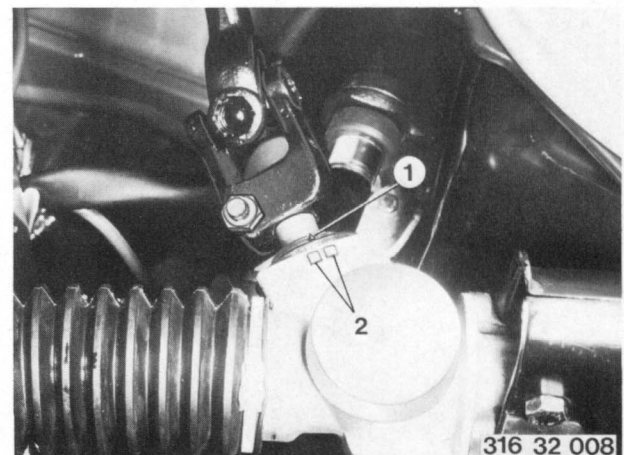

1) See Specifications

32 11 001 REPLACING STEERING GEAR

Remove and install steering gear - 32 11 000.
Clamp Special Tool 32 1 100 in a vise and insert steering gear into special tool. Bend open right lockplate.

Installation Note! Make sure that shoulder from lockplate (1) is in opening of holder (2).

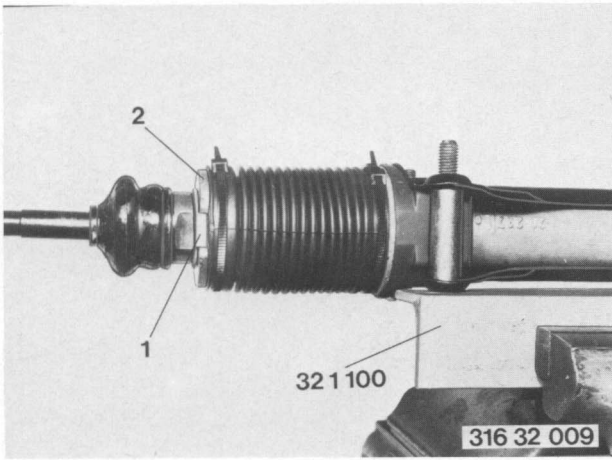

Slide in rack up to stop.
Detach steering damper at holder.
Detach right tie rod at rack with Special Tool 32 2 110.

Installation Note! Tighten to specified torque¹⁾.

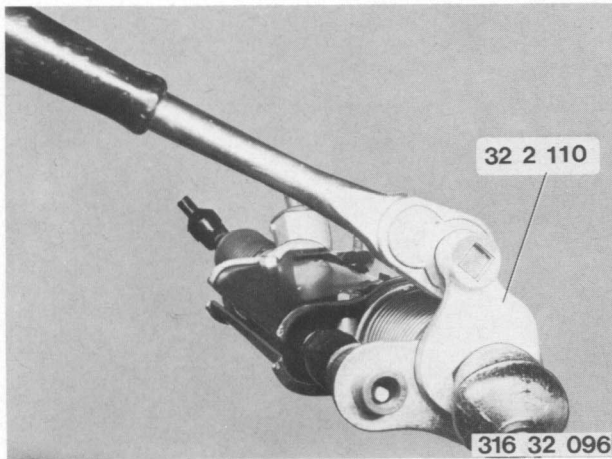

Disconnect harness and remove bellows.

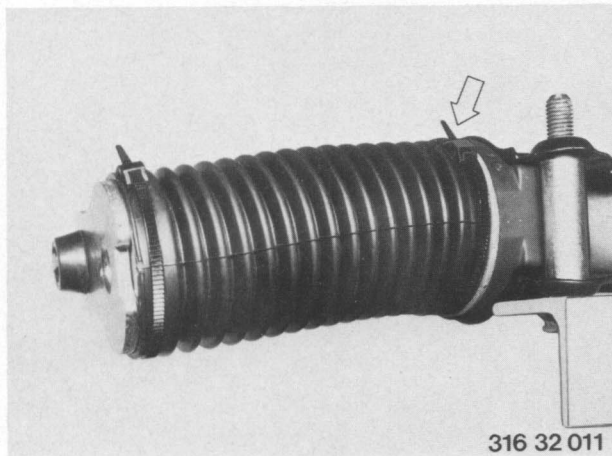

Slide on rack far enough that the special tool can be applied.
Disconnect left harness and slide back bellows.
Bend open lockplate. Detach left tie rod at rack with Special Tool 32 2 100.

Installation Note! Tighten to specified torque¹⁾.

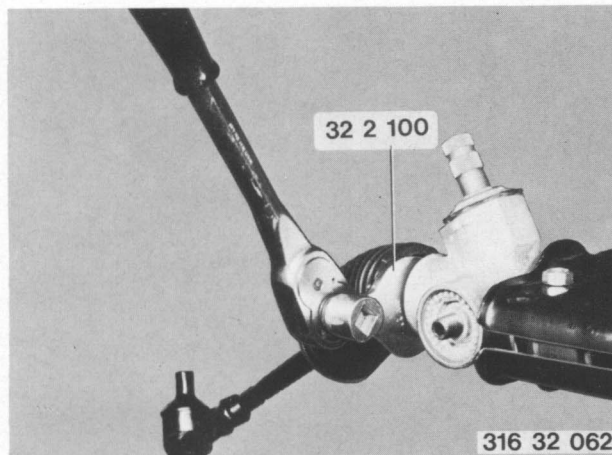

1) See Specifications

Installation Note! Make sure that shoulder (1) is in opening of rack (2).

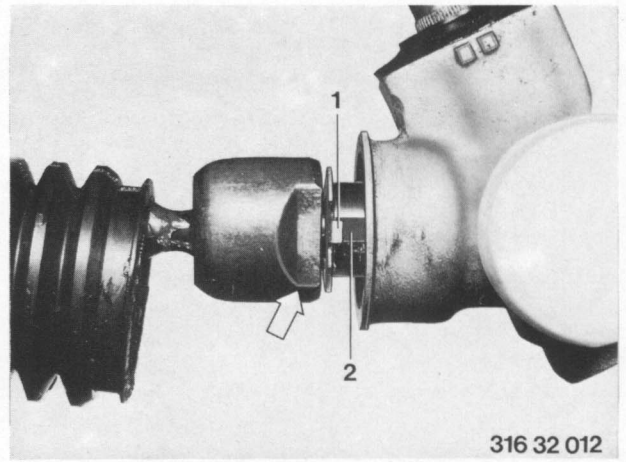

Unscrew nuts and remove bearing plate.

Installation Note! Tighten to specified torque¹⁾.
Replace self-locking nuts.

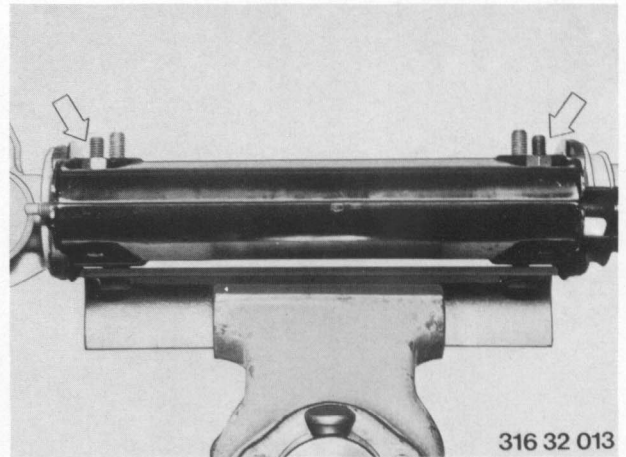

Detach steering damper at steering gear and remove.
Remove rubber bearing (1) and spacer (2).

Installation Note! Check rubber bearing, replace if necessary.

Install rubber bearing (1) that short spacers are in openings provided.

Check and adjust front axle alignment - 32 00 024.

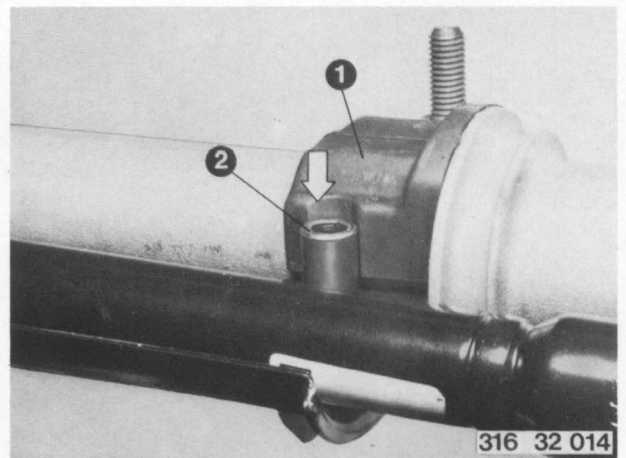

32 11 003 DISASSEMBLING AND ASSEMBLING STEERING GEAR

Remove and install steering gear - 32 11 000.

a) Disassembling Steering

Clamp Special Tool 32 1 100 in a vise and insert steering gear into special tool.

Bend open right lockplate.

Installation Note! Make sure that shoulder of lockplate (1) is in opening of holder (2).

Check and adjust front axle alignment - 32 00 024.

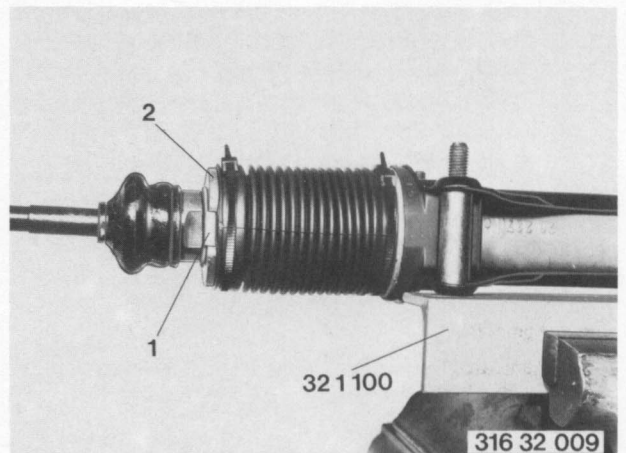

1) See Specifications

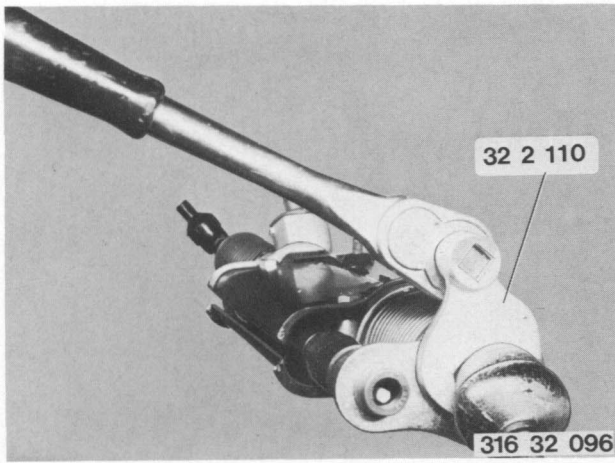

Slide in rack up to stop.
 Detach steering damper at holder.
 Detach right tie rod at rack with Special Tool 32 2 110.

Installation Note! Tighten to specified torque¹⁾.

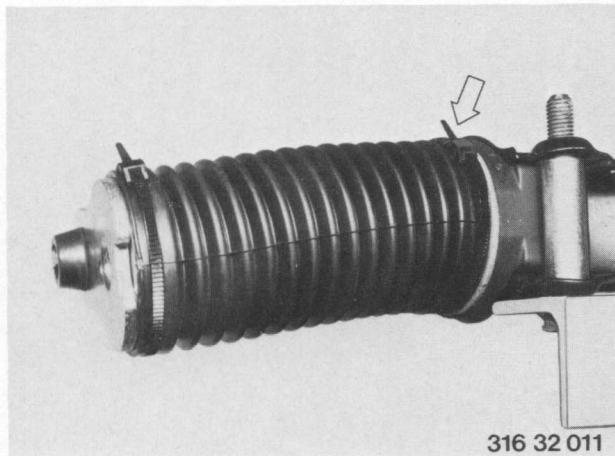

Disconnect harness strap and remove bellows.

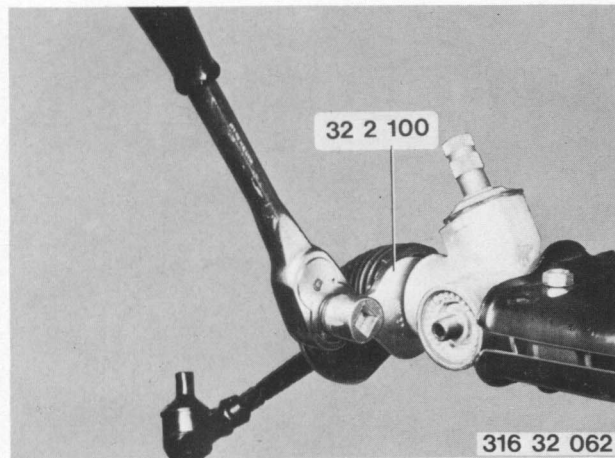

Slide in rack far enough that special tool can be applied.
 Disconnect harness strap and slide back bellows.
 Bend open lockplate.
 Detach left tie rod at rack with Special Tool 32 2 100.

Installation Note! Tighten to specified torque¹⁾.

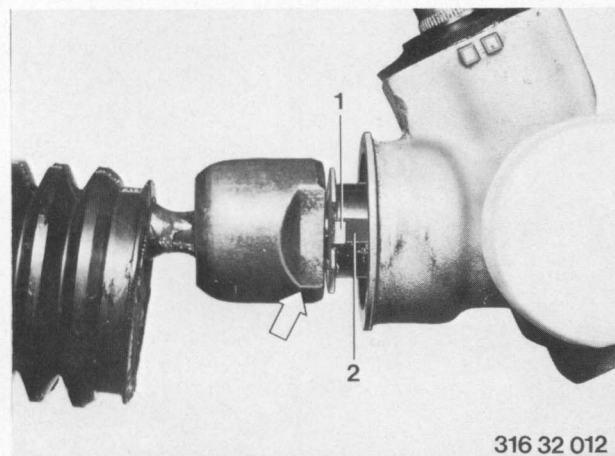

Installation Note! Make sure that shoulder (1) is in opening of rack (2).

1) See Specifications

Remove cap (12).
Pull out cotter pin (10).
Unscrew set screw (9) with Special Tool 32 1 040.
Remove spring retainer (8) and spring (5).

Installation Note! For sequence refer to disassembled steering gear layout drawing on Page 32-11/11.

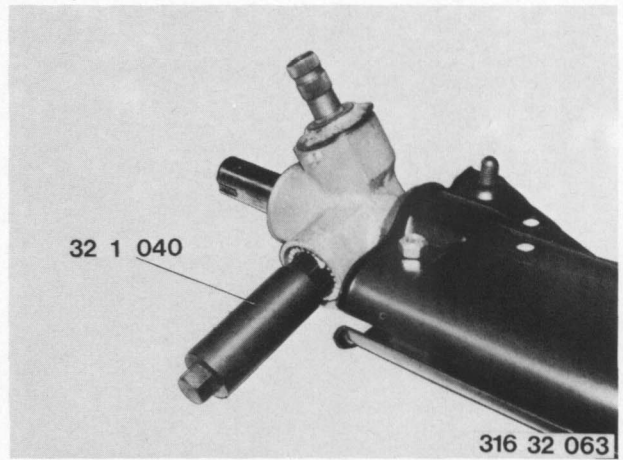

Press pressure pad (6) with o-ring (7) out of bore by lifting rack (2).

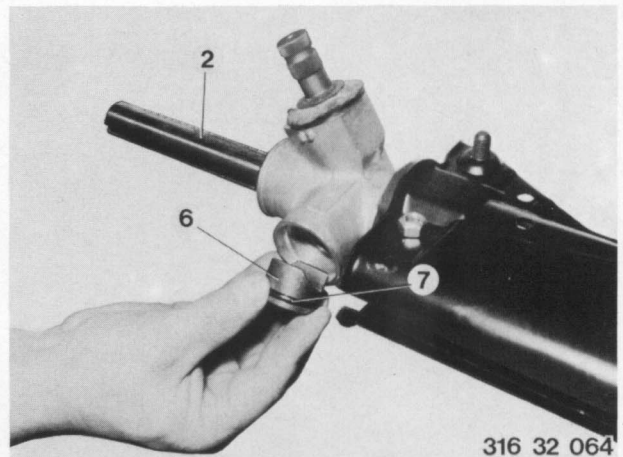

Remove v-ring (22) and press out notched ring (20).

Installation Note! Check v-ring and notched ring, replace if necessary.

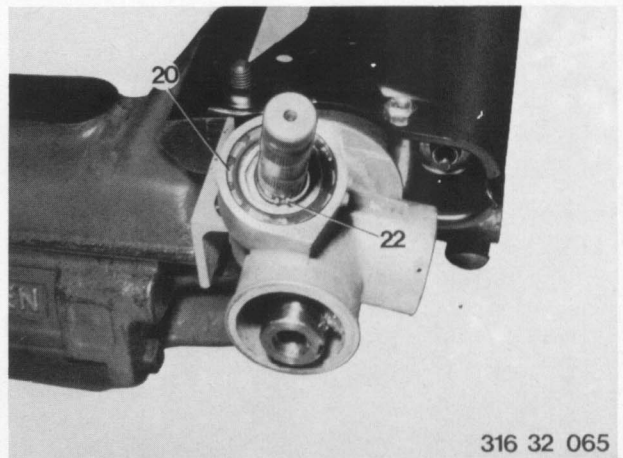

Remove set screw (19) with Special Tool 32 1 040.
Remove o-ring (18) and washer (16).

Installation Note! Tighten to specified torque¹⁾.
For sequence refer to disassembled steering gear layout drawing on Page 32-11/11.

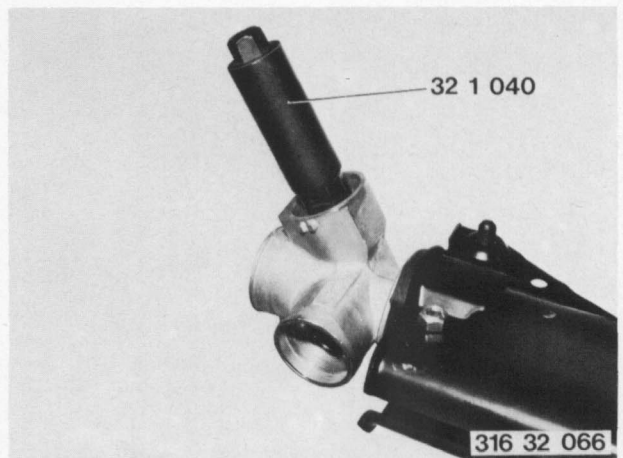

1) See Specifications

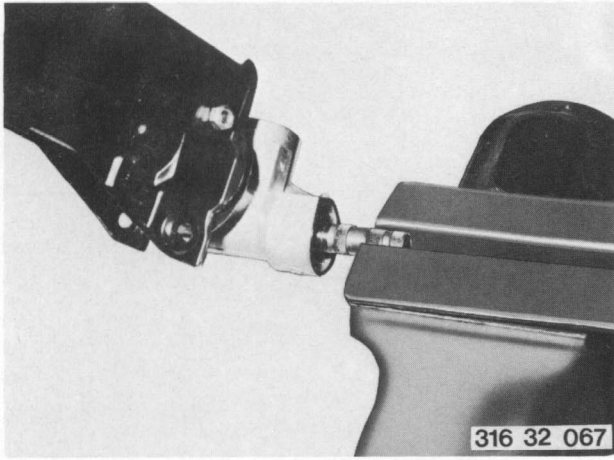

Clamp spline of drive pinion between soft jaws of a vise.
Drive out drive pinion by applying light blows from plastic hammer to box.

Caution! Be careful that rack does not fall out.

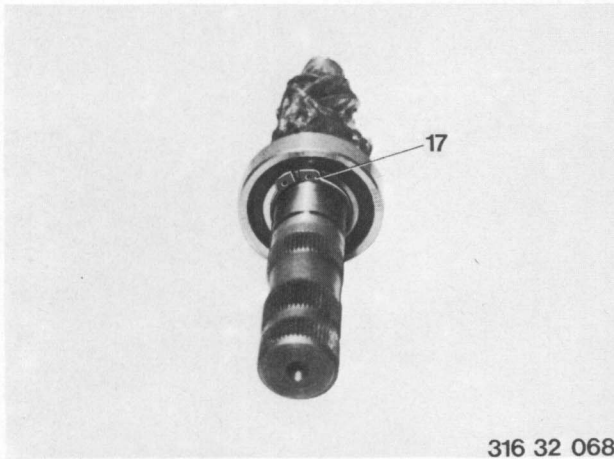

Remove circlip (17).

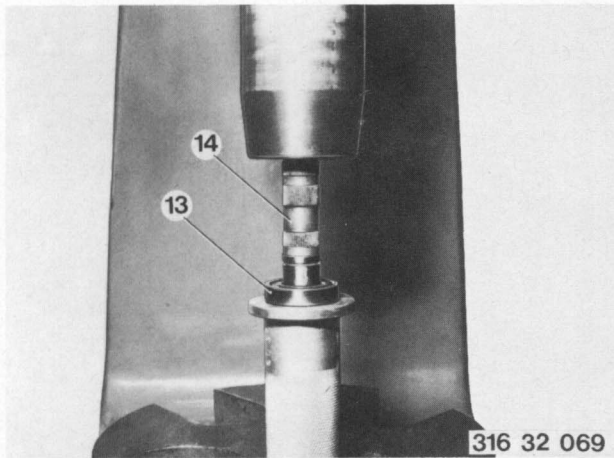

Press grooved ball bearing (13) off of drive pinion (14).

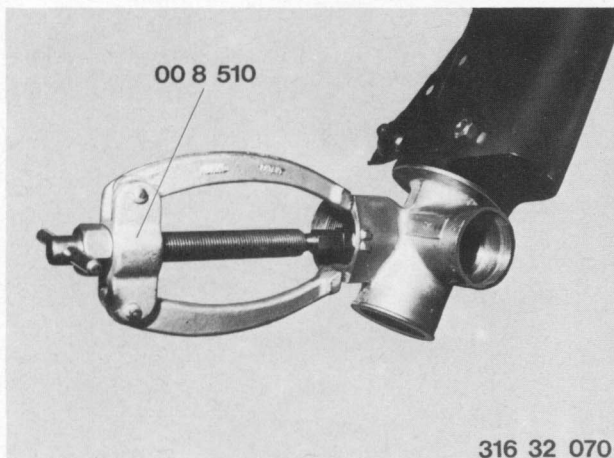

Pull needle bearing race (15) out of box with Kukko extractor 00 8 510.

Press bearing bushing (3) out of locks with 2 screwdrivers, and remove.

Clean thoroughly and inspect all parts before assembling.

Always replace seals and lockplates.

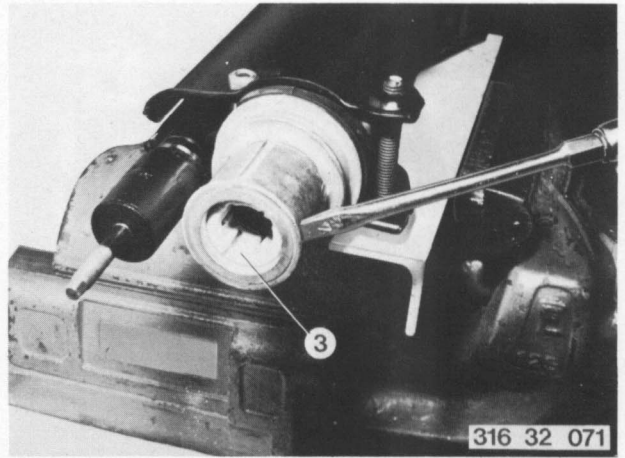

b) Assembling Steering

Install new o-rings (4) in bearing bushing (3).
Install bearing bushing in steering box that tabs engage in locks.

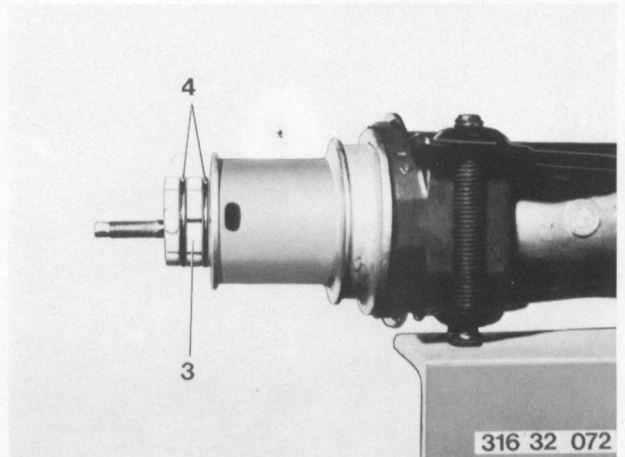

Drive needle bearing race (15) into box with an appropriate mandrel that its flat side faces down.

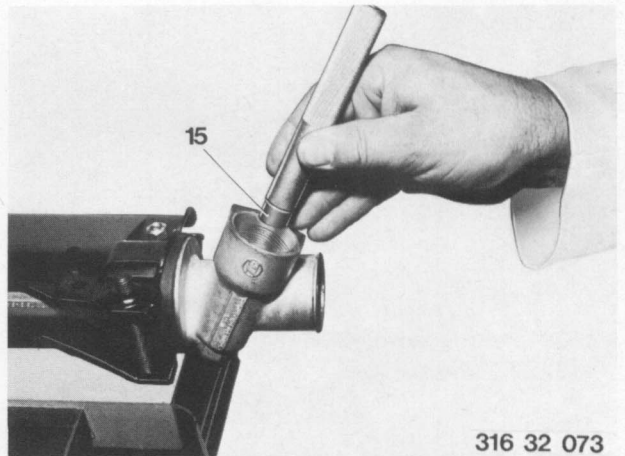

Press grooved ball bearing (13) onto drive pinion (14) with closed end facing spline and install circlip (17).

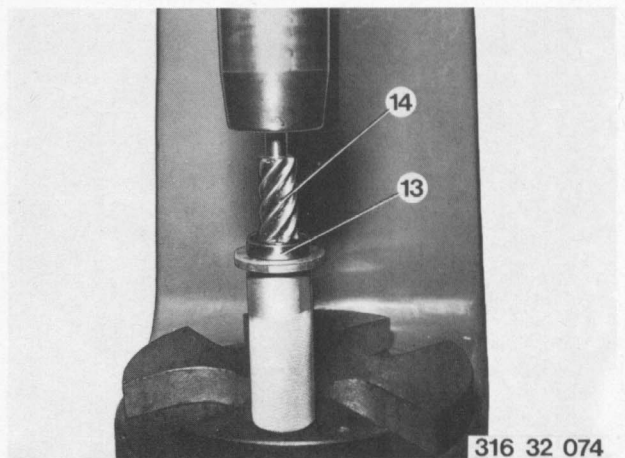

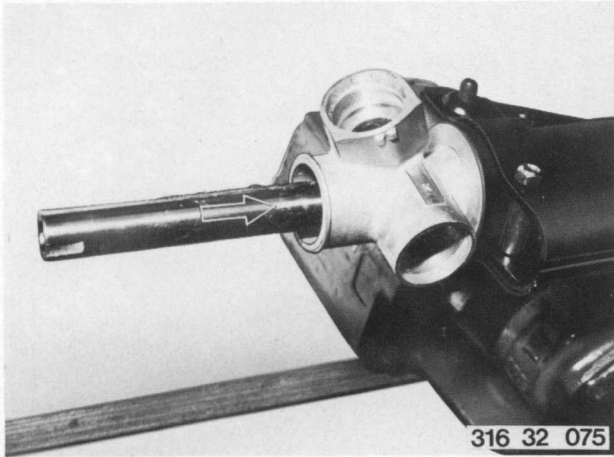

Apply grease ¹⁾ thickly to spline surface if rack and
thinly to remaining surface.
Install rack in box.

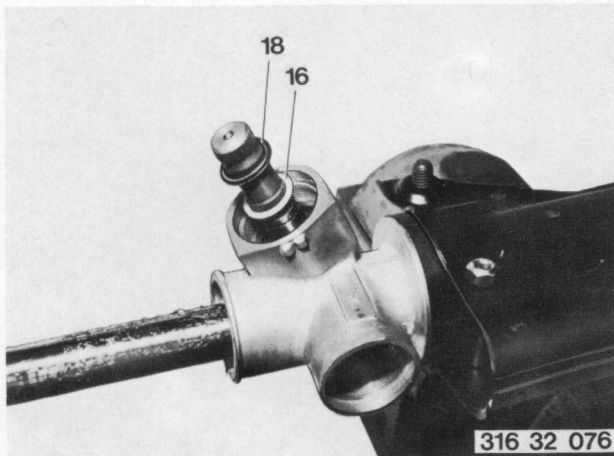

Dip pinion (14) with preassembled grooved ball bearing (13) in grease 1) and then install in box.
Slide plastic washer (16) and o-ring (18) on pinion (14).

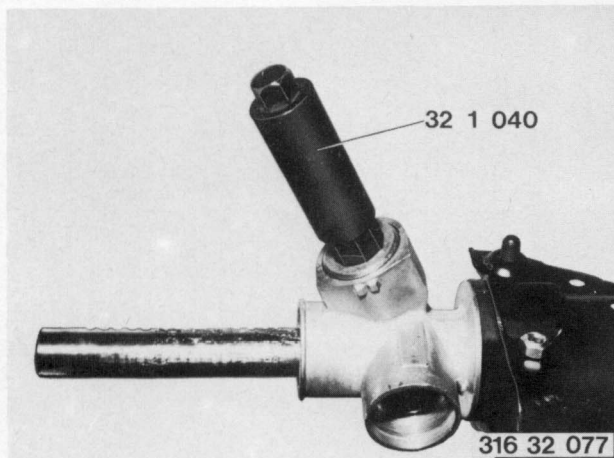

Tighten set screw (19) with Special Tool 32 1 040.
Installation Note! Tighten to specified torque ¹⁾.

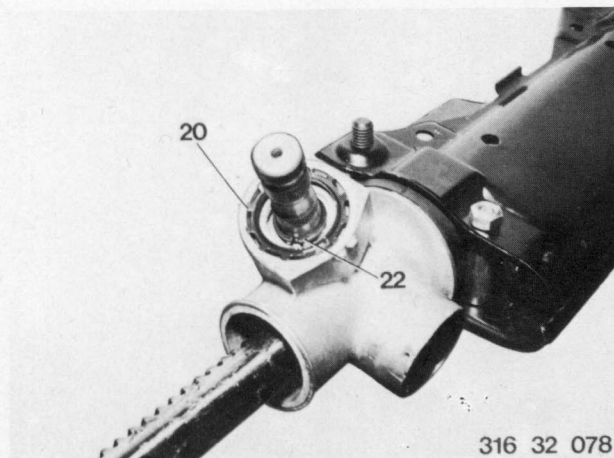

Insert v-ring (22) up to groove.
Press in notched ring (20) up to stop.

1) See Specifications

Move rack to center position.
Distance A = 77 mm (3.031").
Fill cavity between dust seal (21) and notched ring (20) with grease 1).
Slide on dust seal that mark on dust seal is between marks on steering box.

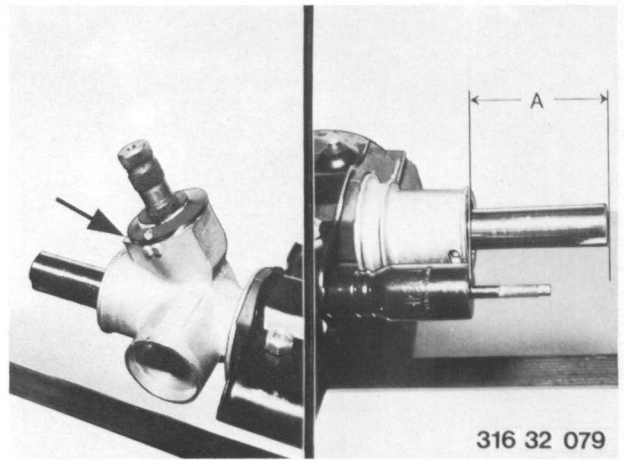

Insert o-ring (7) into pressure pad (6) and slide pressure pad into steering box.

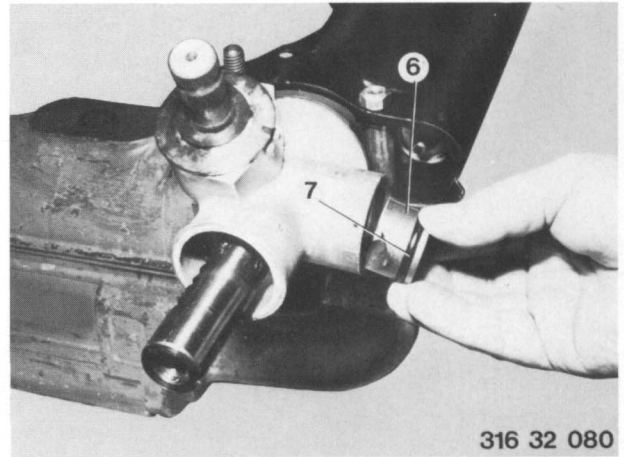

Place spring (5) and spring retainer (8) on pressure pad.

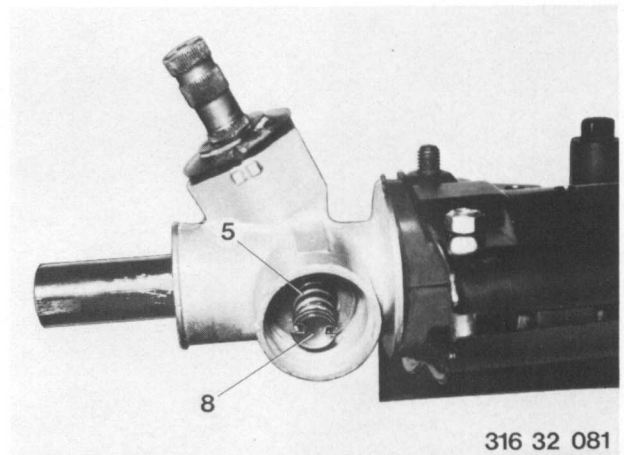

Tighten set screw (9) against stop.
Back off set screw (11).
Distance B = approx. 12 mm (1/2").

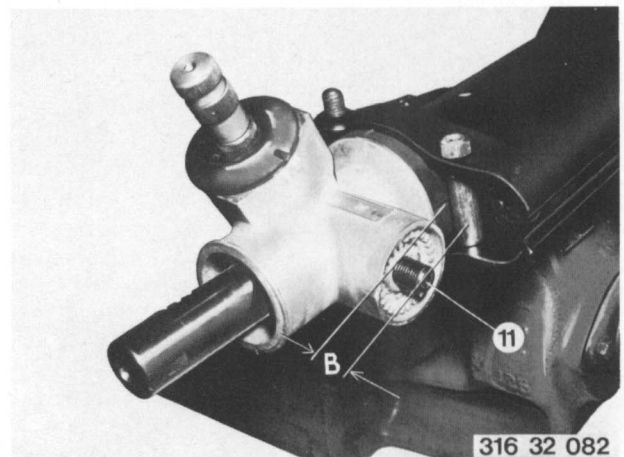

1) See Specifications

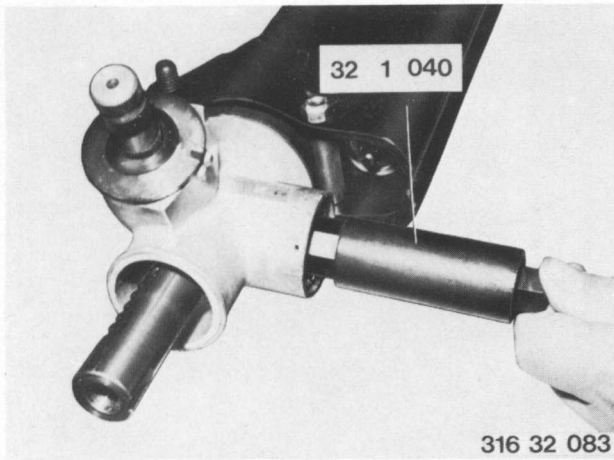

Tighten set screw (9) to 6 Nm / 0.6 mkp (4 ft. lbs.) with Special Tool 32 1 040 and back off by one castle slot to cotter pin bore.

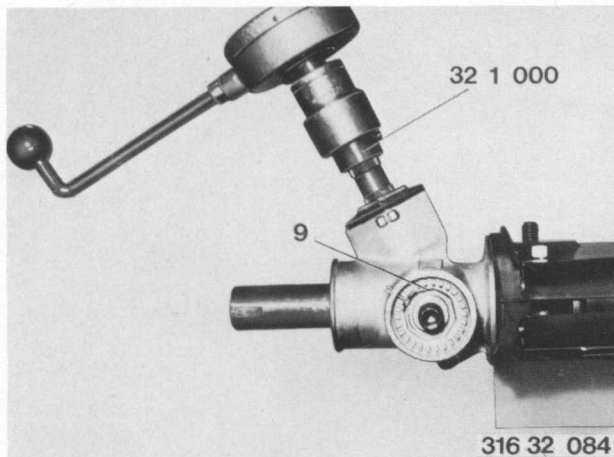

Using Special Tool 32 1 000 turn rack to the left and right over the entire length, and check for sticking and hooking.

If this is the case, loosen screw by one more castle slot and insert cotter pin.

Repeat test. If there is still sticking or hooking, replace rack or perhaps entire steering gear.

Never loosen screw to another castle slot regardless of circumstances.

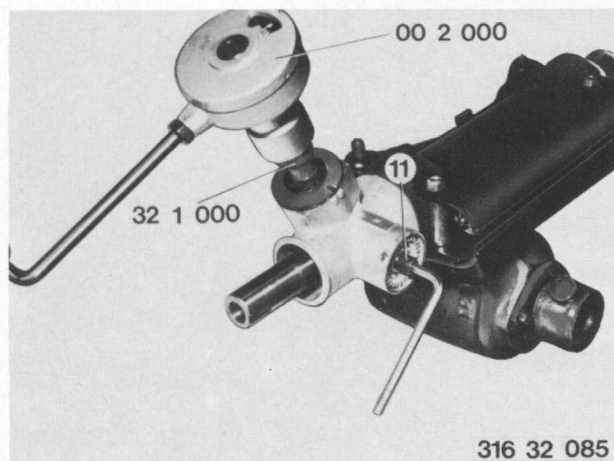

c) Turning Torque Adjustment

Move rack to center position. Mount Special Tools 00 2 000 and 32 1 000 on drive pinion.

Determine turning torque 1). If specified friction value 1) is not reached, adjust set screw (11).

Turn to the right = more friction

Turn to the left = less friction

Install cap (12).

Note! Set screw (11) is self-locking.

Replace when it is no longer tight.

Attach tie rods to rack.

1) See Specifications

Disassembled Steering Gear Layout Drawing

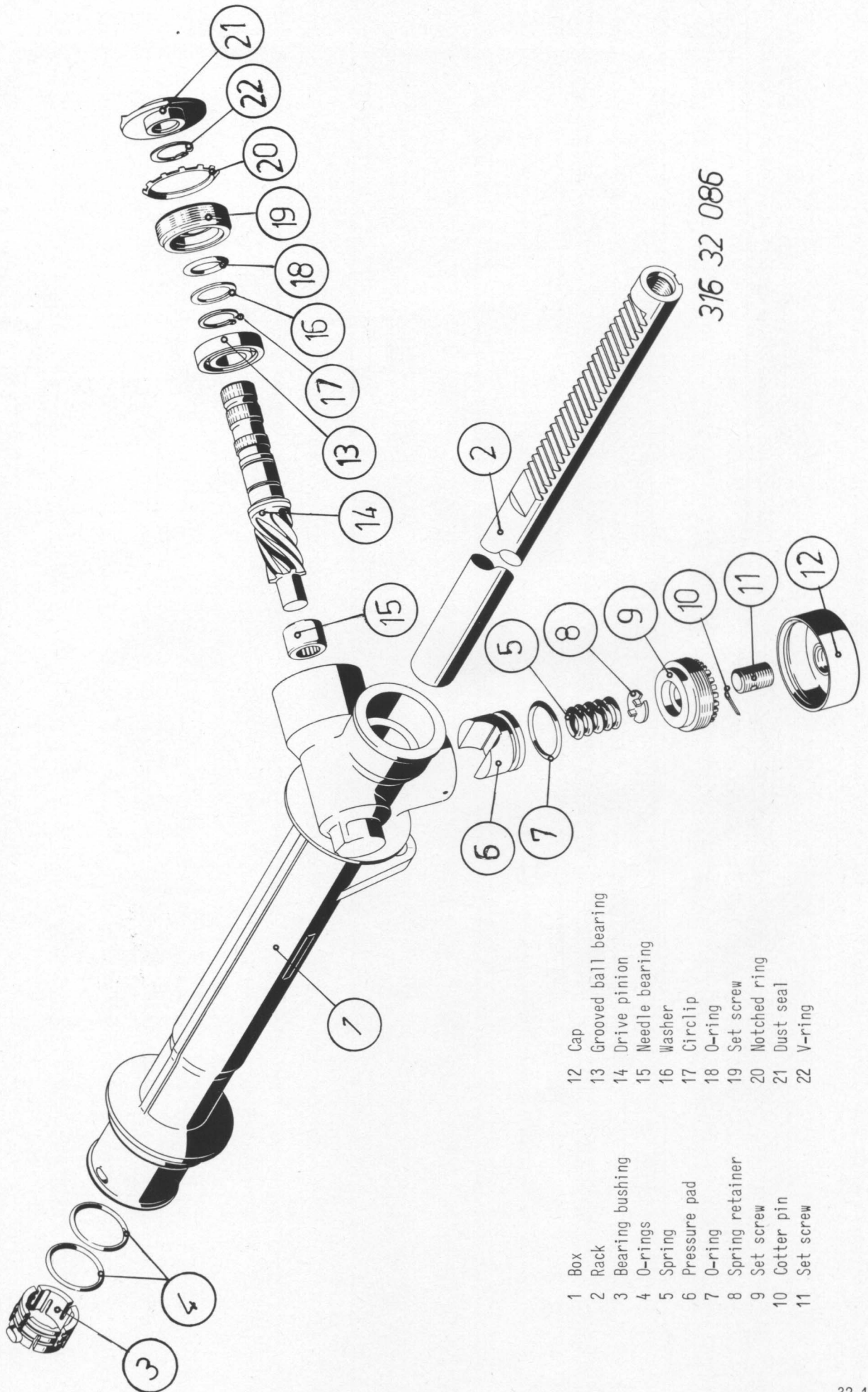

316 32 086

- | | | | |
|----|-----------------|----|----------------------|
| 1 | Box | 12 | Cap |
| 2 | Rack | 13 | Grooved ball bearing |
| 3 | Bearing bushing | 14 | Drive pinion |
| 4 | O-rings | 15 | Needle bearing |
| 5 | Spring | 16 | Washer |
| 6 | Pressure pad | 17 | Circlip |
| 7 | O-ring | 18 | O-ring |
| 8 | Spring retainer | 19 | Set screw |
| 9 | Set screw | 20 | Notched ring |
| 10 | Cotter pin | 21 | Dust seal |
| 11 | Set screw | 22 | V-ring |

Cross Section Drawing of Assembled Steering Gear

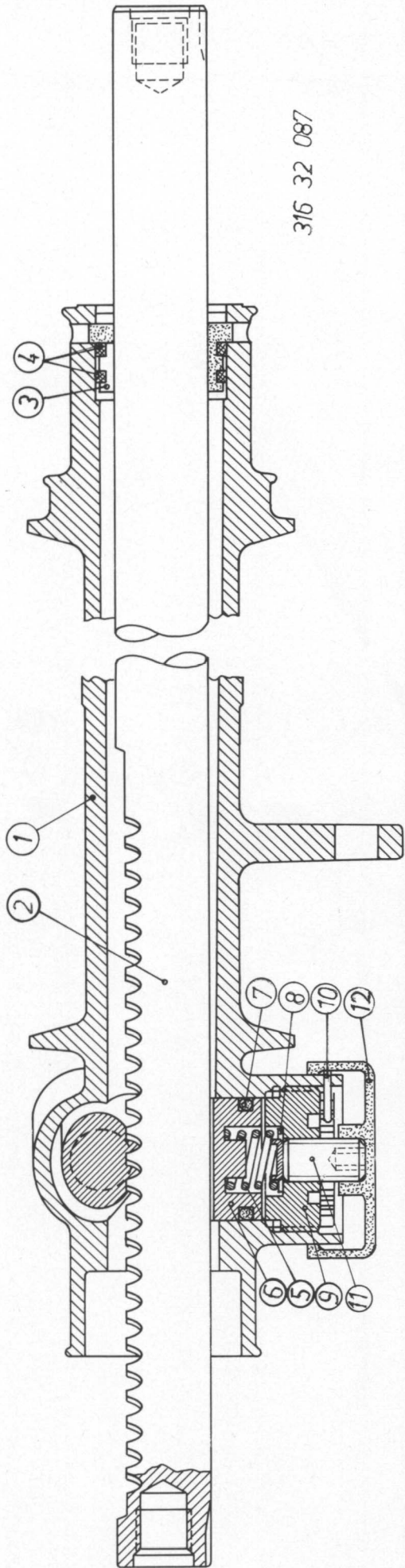

316 32 087

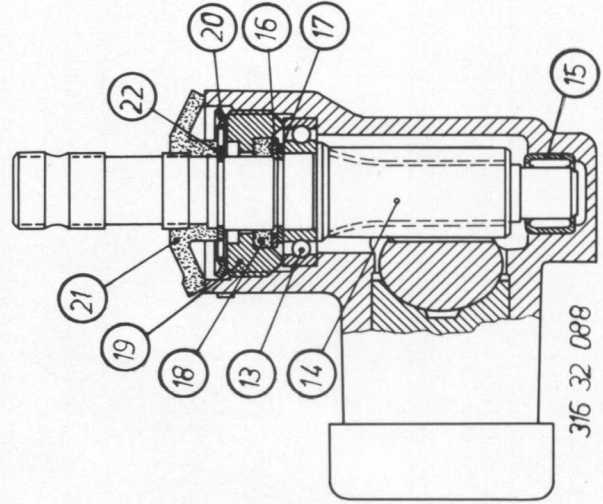

316 32 088

- | | | | |
|----|-----------------|----|----------------------|
| 1 | Box | 12 | Cap |
| 2 | Rack | 13 | Grooved ball bearing |
| 3 | Bearing bushing | 14 | Drive pinion |
| 4 | O-rings | 15 | Needle bearing |
| 5 | Spring | 16 | Washer |
| 6 | Pressure pad | 17 | Circlip |
| 7 | O-ring | 18 | O-ring |
| 8 | Spring retainer | 19 | Set screw |
| 9 | Set screw | 20 | Notched ring |
| 10 | Cotter pin | 21 | Dust seal |
| 11 | Set screw | 22 | V-ring |

32 21 231 REPLACING LEFT TIE ROD

Loosen left front wheel.
Remove cotter pin and unscrew castle nut.
Press tie rod off of steering knuckle with Special Tool 32 2 050.

Installation Note! Check and adjust front axle alignment - 32 00 024.
Tighten to specified torque¹⁾.

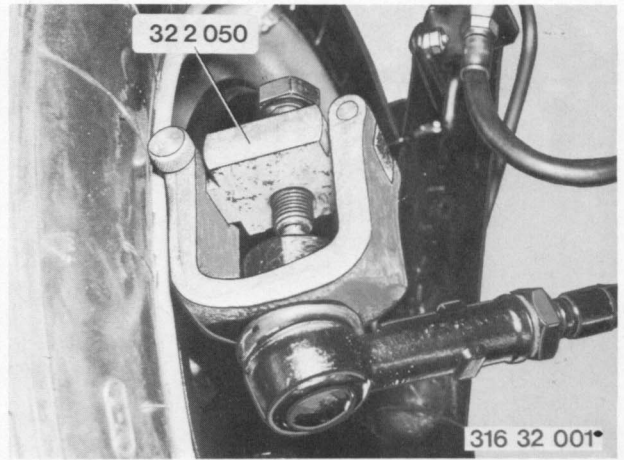

Detach strap and slide back bellows.
Bend open lockplate.
Slide in tie rod far enough that special tool can be applied.
Detach tie rod at rack with Special Tool 32 2 100.

Installation Note! Tighten to specified torque¹⁾.
Make sure that shoulder of lockplate is in opening of rack.
Check strap and bellows, replace if necessary.

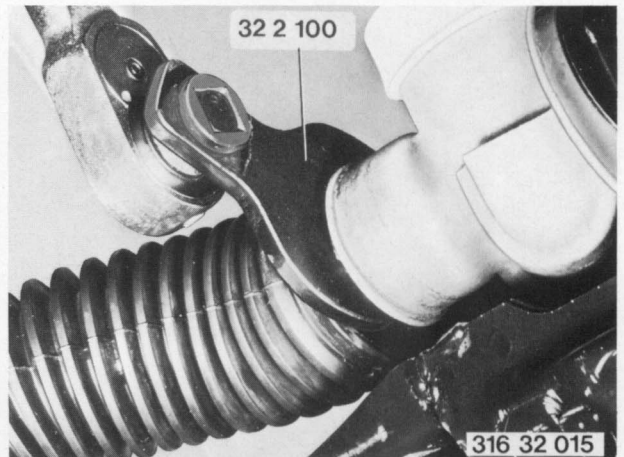

32 21 241 REPLACING RIGHT TIE ROD

Loosen right front wheel.
Remove cotter pin and unscrew castle nut.
Press tie rod off of steering knuckle with Special Tool 32 2 050.

Installation Note! Check and adjust front axle alignment - 32 00 024.
Tighten to specified torque¹⁾.

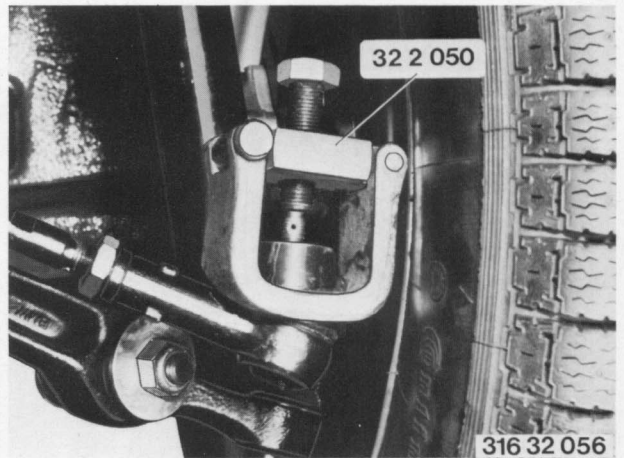

Unscrew nut and slide back steering damper.
Bend open lockplate.
Slide in rack up to stop.
Detach tie rod at rack with Special Tool 32 2 110.

Installation Note! Tighten to specified torque¹⁾.
Make sure that shoulder of lockplate is in opening of holder.

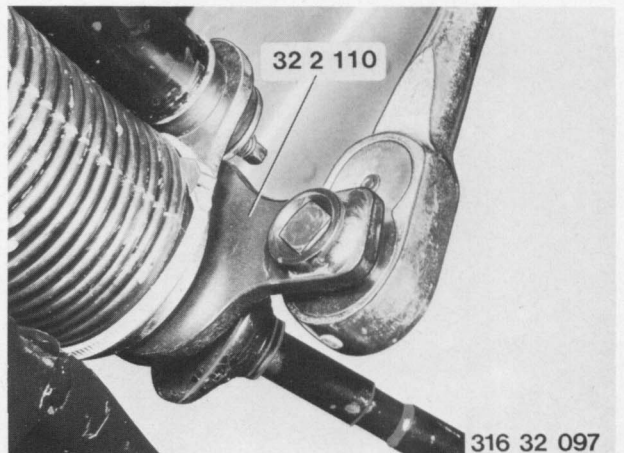

1) See Specifications

32 31 000 REMOVING AND INSTALLING UPPER STEERING COLUMN CASING

Disconnect minus cable at battery.
Remove and install steering wheel - 32 33 000.
Remove and install lower column casing - 32 31 020.
Detach windshield wiper and turn signal switch at switch plate.

Installation Note! See installation notes for replacing cancelling cam - 32 31 131.

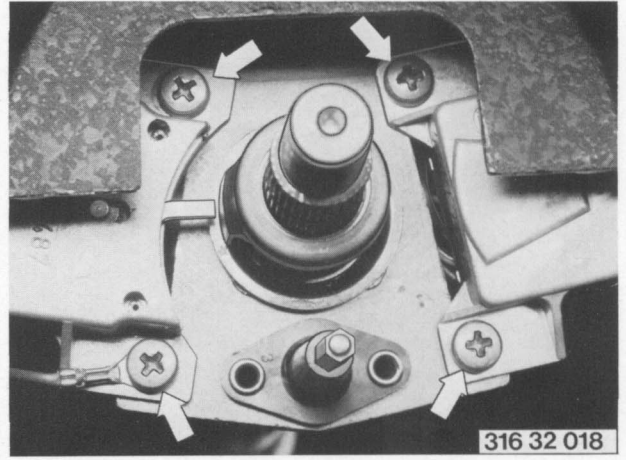

Detach shear-off head bolts with a chisel or similar tool.

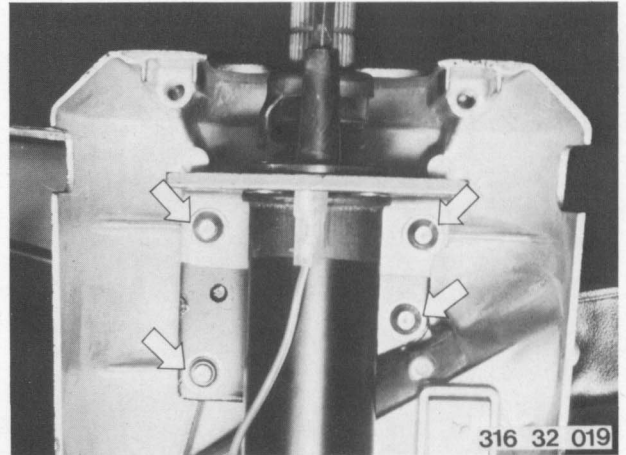

Unscrew hollow set screw and pull out ignition switch.

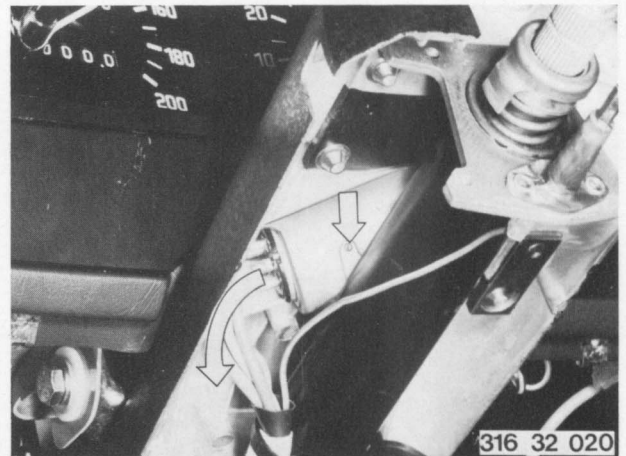

Detach shear-off head bolts with a chisel or similar tool and remove upper column casing.

Installation Note! Align upper casing and casing tube. Don't tension.
Tighten to specified torque¹⁾.

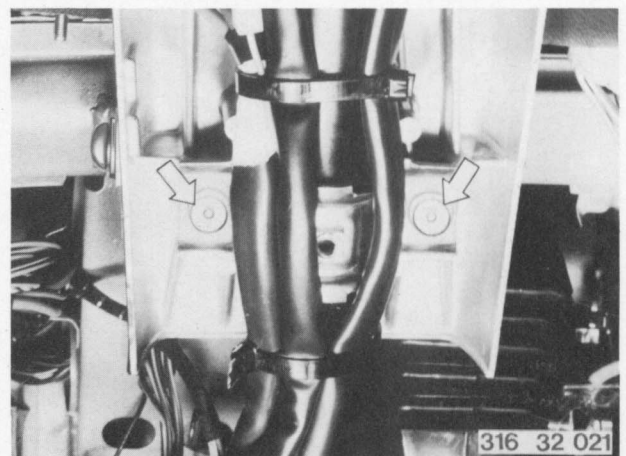

1) See Specifications

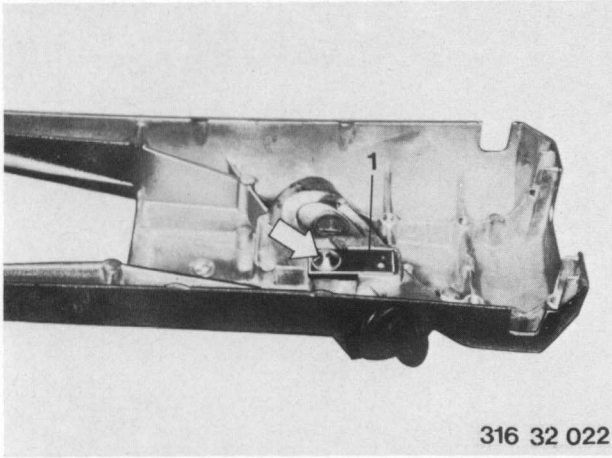

32 31 001 REPLACING UPPER STEERING COLUMN CASING

Remove and install upper casing - 32 31 000.
 Detach shear-off head bolts with a chisel or similar tool.
 Remove plate (1) and pull out steering lock.

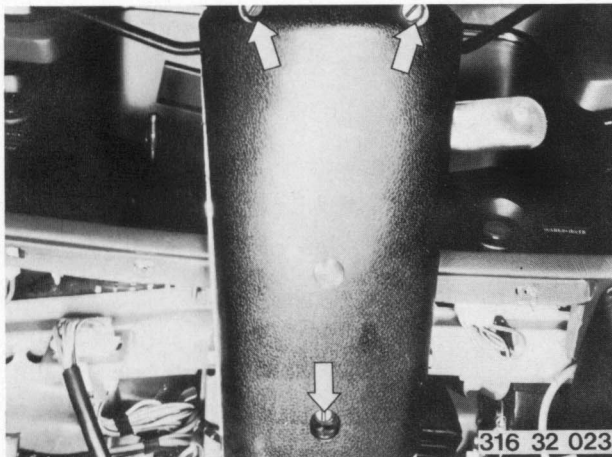

32 31 020 REMOVING AND INSTALLING LOWER STEERING COLUMN CASING

Detach and attach bottom center instrument panel trim - 51 45 190.
 Loosen mounting screws and remove lower column casing.

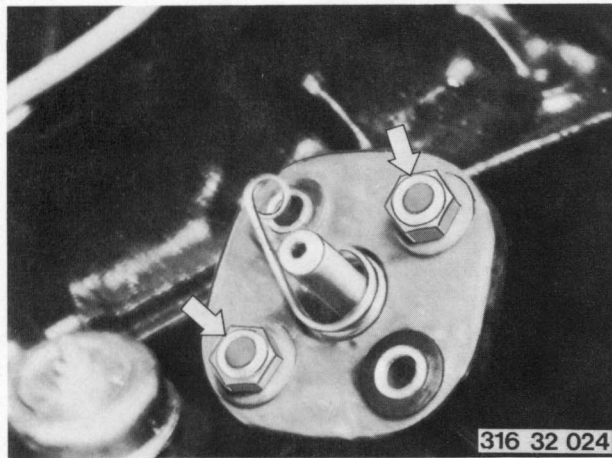

32 31 051 REPLACING COUPLING

Remove and install steering spindle universal joint - 32 31 211.
 Unscrew nuts and remove coupling.
Installation Note! Tighten to specified torque ¹⁾.
 Note location of ground spring.
 Replace self-locking nuts.

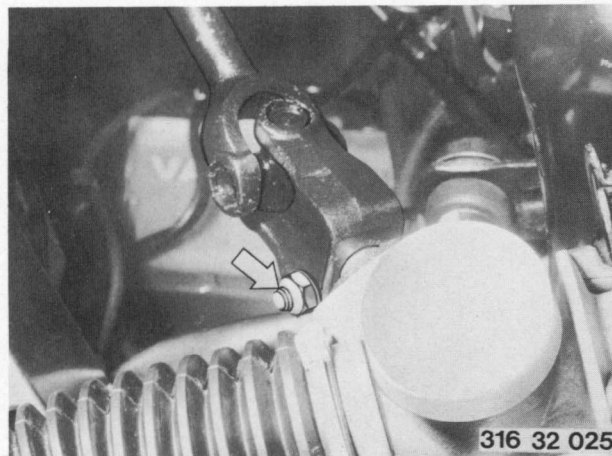

32 31 070 REMOVING AND INSTALLING LOWER STEERING SPINDLE

Remove and install coupling - 32 31 051.
 Unscrew nut and pull out bolt.
 Push steering spindle off of steering.
Installation Note! Replace self-locking nut.
 Tighten to specified torque 1).

1) See Specifications

32 31 080 REPLACING STEERING SPINDLE

Remove and install steering column - 32 31 090.
Remove cancelling cam (1), collar ring (2), snap ring (3), washer (4) and spring (5).

Installation Note! Make sure that snap ring (3) is in recess of collar ring (2).

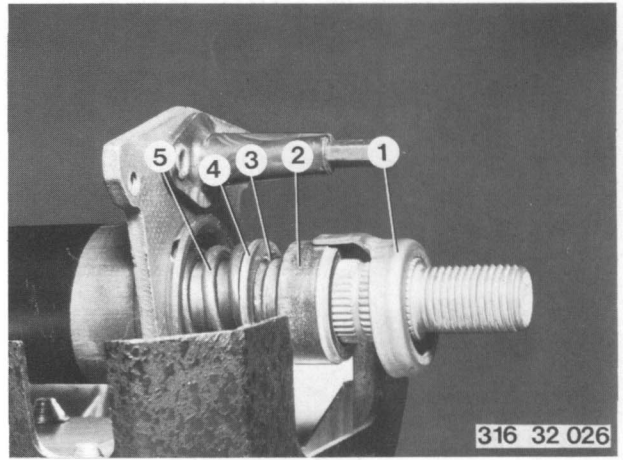

Press out steering spindle bearing.

Installation Note! Stem of ring (6) faces steering spindle bearing (7).

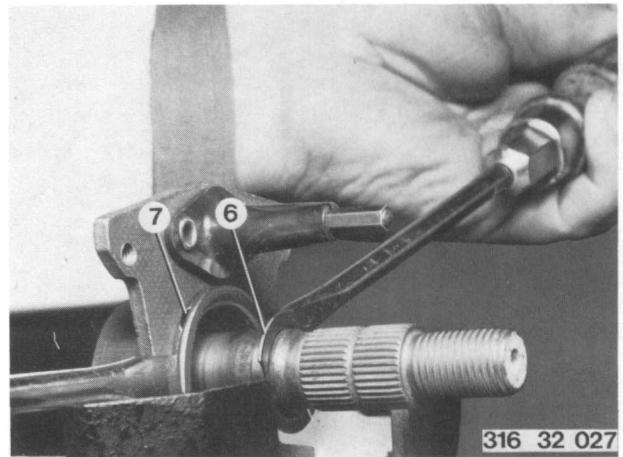

Take snap ring (1), ring (2) and lower steering spindle bearing (3) off of steering spindle.

Installation Note! Stem of ring (2) faces steering spindle bearing (3).

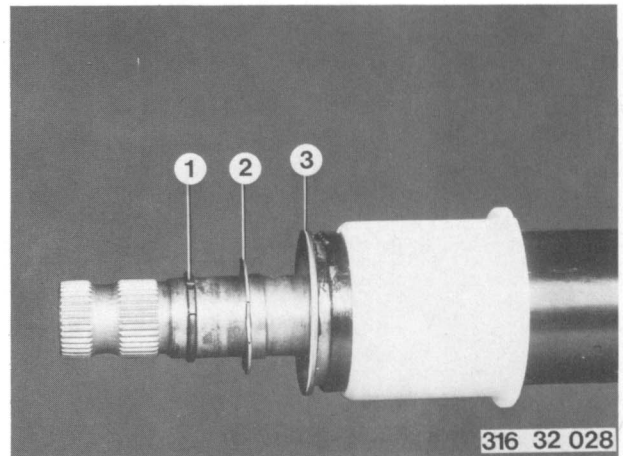

Installation Note! Install snap ring with Special Tool 32 3 050.

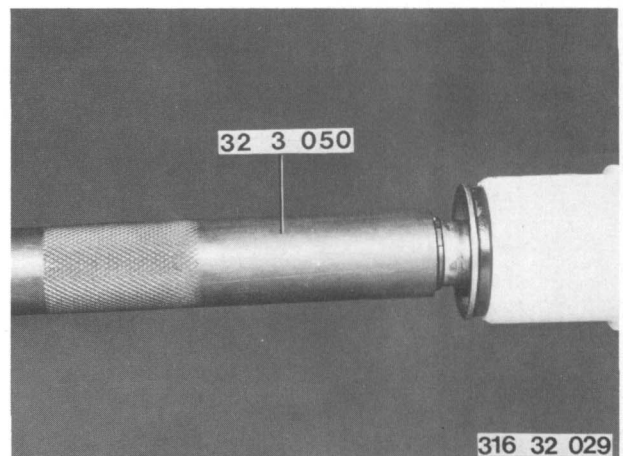

32 31 090 REMOVING AND INSTALLING STEERING COLUMN

Disconnect minus cable at battery.
Remove and install lower column casing - 32 31 020.
Remove and install steering wheel - 32 33 000.
Detach windshield wiper and turn signal switch at switch plate.

Installation Note! See installation notes for replacing cancelling cam - 32 31 131.

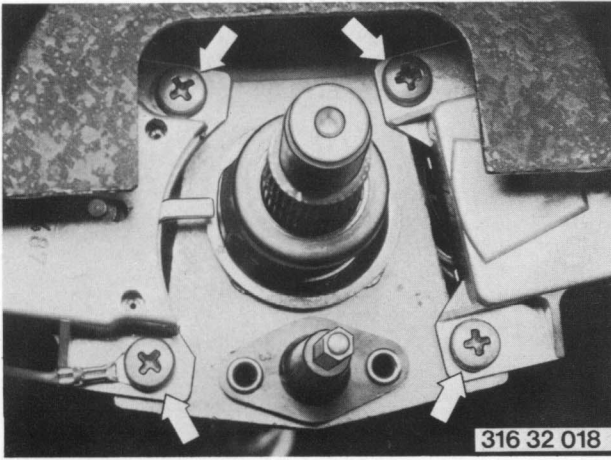

Detach shear-off head bolts with a chisel or similar tool.

Remove harness straps.

Installation Note! Tighten to specified torque¹⁾.
Align upper column casing and casing tube. Don't tension.
Replace straps.

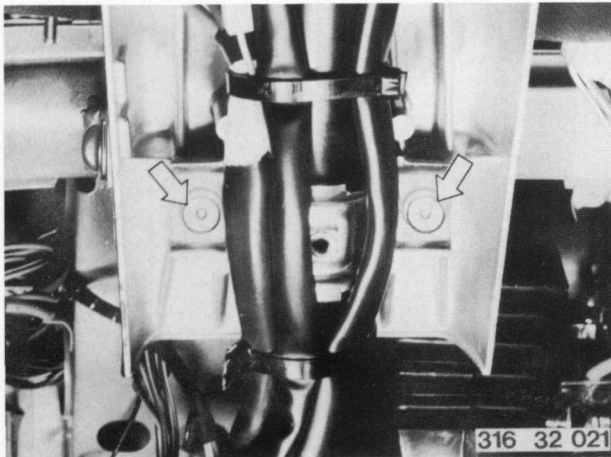

Unscrew hollow set screw and pull out ignition switch.

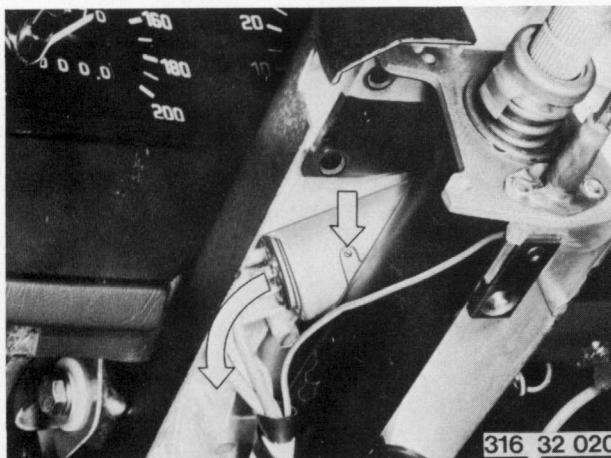

Detach casing tube clamp at base.

Installation Note! Tighten to specified torque¹⁾.

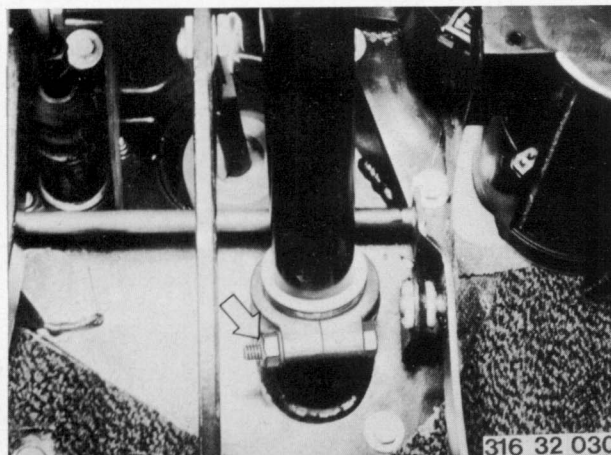

1) See Specifications

Loosen screw and push steering spindle with casing tube off of universal joint.

Installation Note! Tighten to specified torque¹⁾.
Make sure that screw is in locking groove.

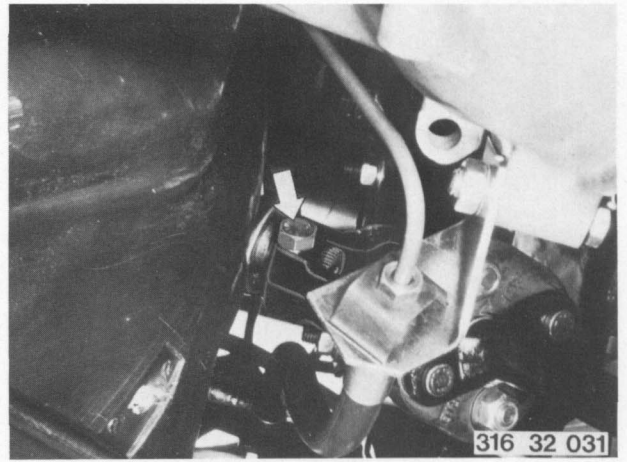

32 31 131 REPLACING TURN SIGNAL SWITCH CANCELLING CAM

Remove and install steering wheel - 32 33 000.
Pull off cancelling cam.

Installation Note!

- a) Steering wheel with road wheels pointing straight ahead.
- b) Turn signal switch in center position.
- c) Dog points to center of cancelling cam.
- d) Adjust distance A to about 3 mm (0.118") with turn signal switch.

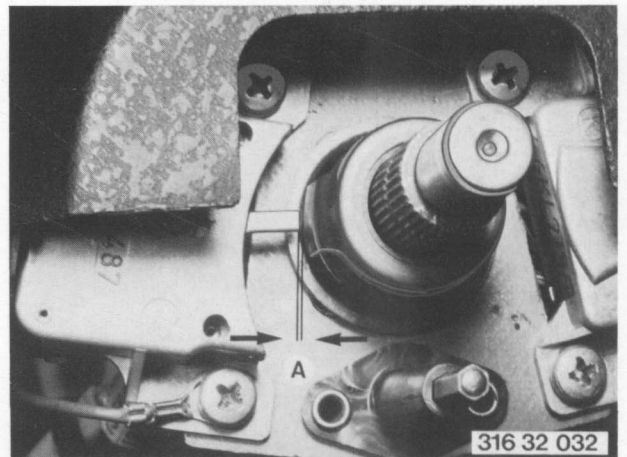

32 31 151 REPLACING UPPER STEERING SPINDLE BEARING

Remove and install lower column casing - 32 31 020.
Remove and install steering wheel - 32 33 000.
Pull off cancelling cam (1) and collar ring (2).
Remove snap ring (3).

Installation Note! See installation notes for replacing cancelling cam - 32 31 131.

Snap ring (3) engages in recess of collar ring (2).

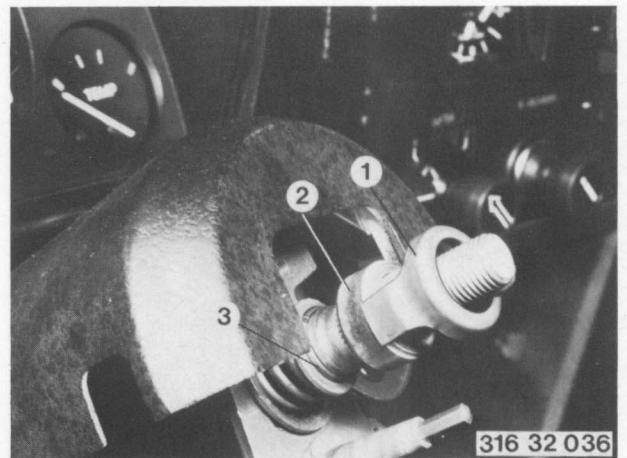

Remove washer (4), spring (5) and ring (6).
Lift steering spindle bearing (7) out of casing tube.

Installation Note! Stem of ring (6) faces steering spindle bearing.

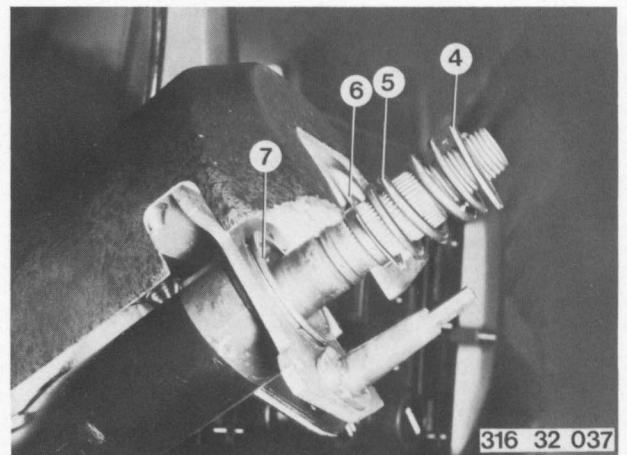

1) See Specifications

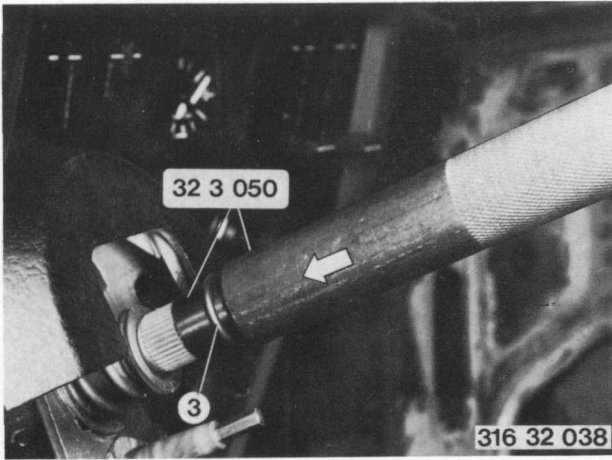

Installation Note! Press in steering spindle bearing until flush.
Install Special Tool 32 3 050 on steering spindle and press snap ring (3) into steering spindle groove.

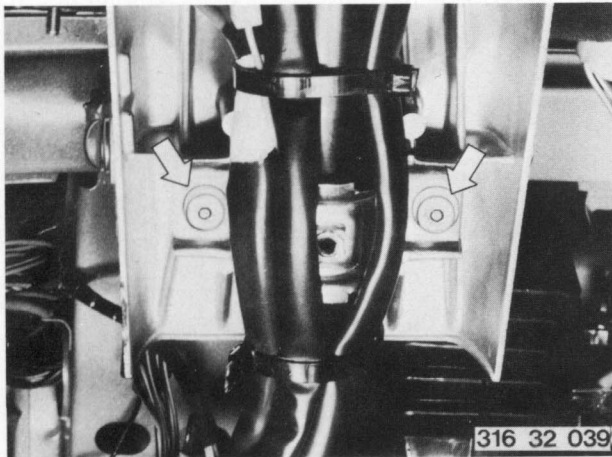

32 31 161 REPLACING LOWER STEERING SPINDLE BEARING

Remove and install upper steering spindle bearing, see replacing - 32 31 151.
Detach shear-off head screws with a chisel or similar tool.

Installation Note! Align upper column casing and casing tube. Don't tension.¹⁾
Tighten to specified torque.

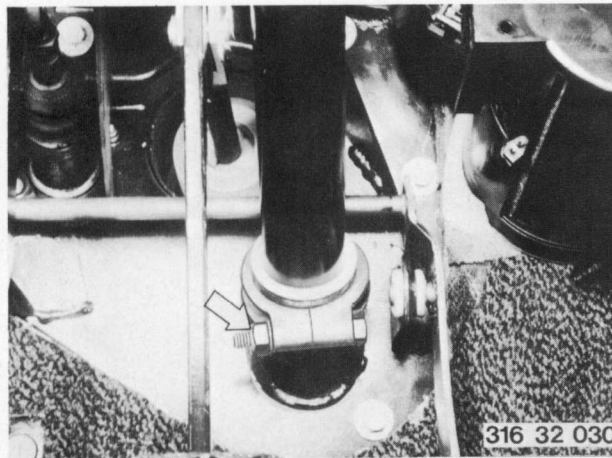

Detach casing tube clamp at base.

Installation Note! Tighten to specified torque¹⁾.

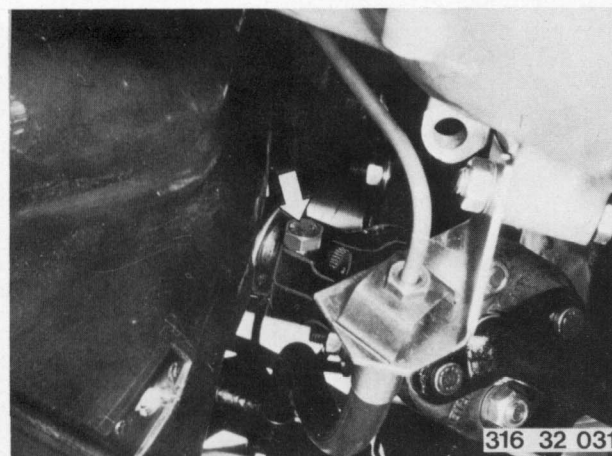

Loosen screw and push steering spindle with casing tube off of universal joint.

Installation Note! Make sure that screw is in locking groove.
Tighten to specified torque¹⁾.

1) See Specifications

Drive out steering spindle bearing with steering spindle downward.
Remove snap ring (1), ring (2) and steering spindle bearing (3).

Installation Note! Stem of ring (2) faces steering spindle bearing.

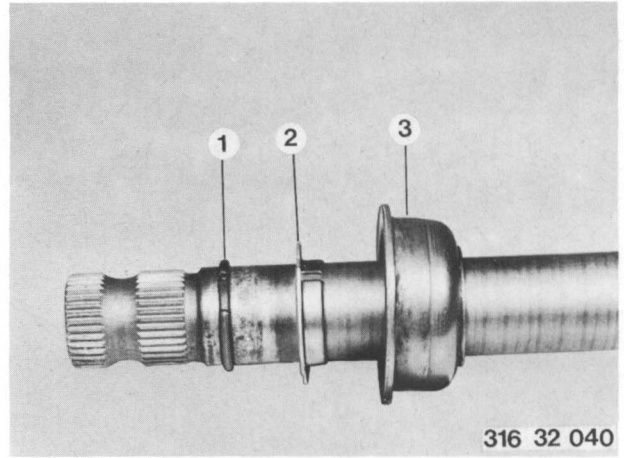

Install snap ring (1) in locking groove with Special Tool 32 3 050.

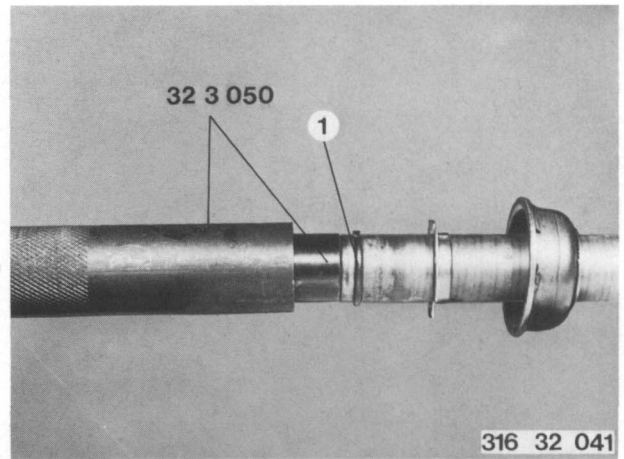

32 31 211 REPLACING STEERING SPINDLE UNIVERSAL JOINT

Detach and attach bottom center instrument panel trim - 51 45 190.
Detach shear-off head screws with chisel or similar tool.

Installation Note! Tighten to specified torque¹⁾.
Install steering column as far back as possible.



Detach casing tube clamp at base.

Installation Note! Tighten to specified torque¹⁾.

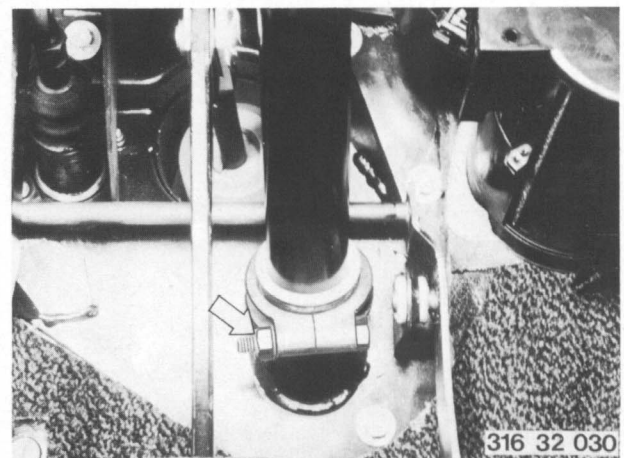

1) See Specifications

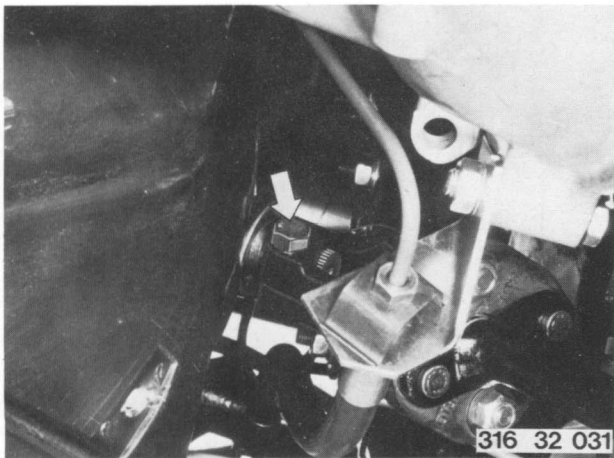

Loosen screw and push steering spindle with casing tube off of universal joint.

Installation Note! Make sure that screw is in locking groove.
Tighten to specified torque 1).

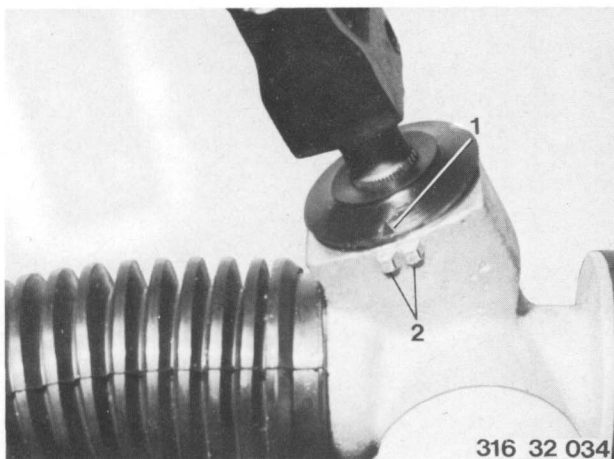

Installation Note! Set steering wheel that wheels point straight ahead.
Mark (1) on dust seal must be between marks (2) on steering box.

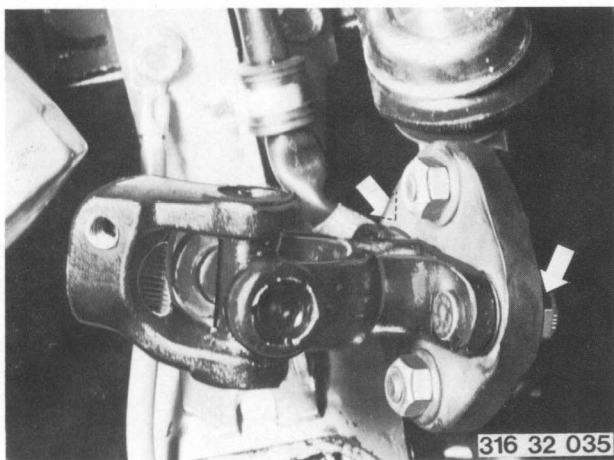

Loosen nuts and remove universal joint.

Installation Note! Replace self-locking nuts.
Tighten to specified torque 1).

1) See Specifications

32 32 000 REMOVING AND INSTALLING STEERING LOCK

Remove and install upper column casing - 32 31 000.
Detach shear-off head screw with a chisel or similar tool.
Remove plate (1) and pull out steering lock.

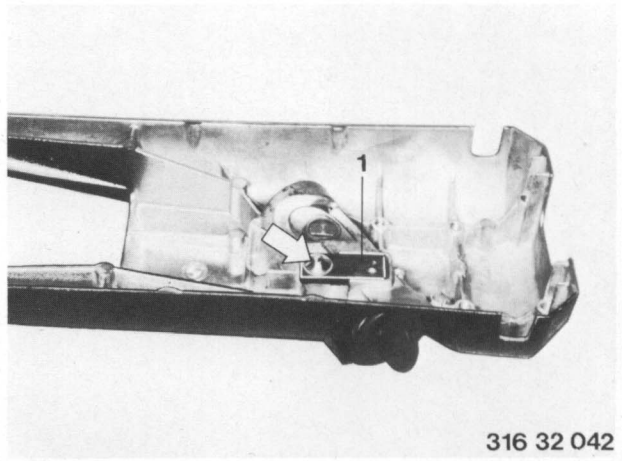

32 32 050 REMOVING AND INSTALLING STEERING LOCK CYLINDER

Remove and install steering lock - 32 32 000.
Press in locking spring on cylinder and remove lock cylinder.

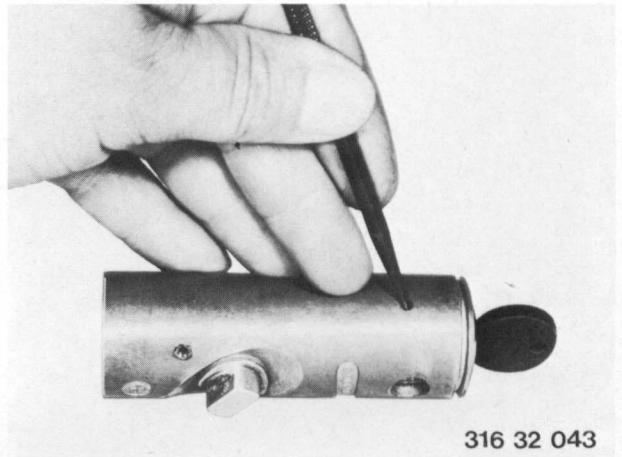

Note engraved key number.

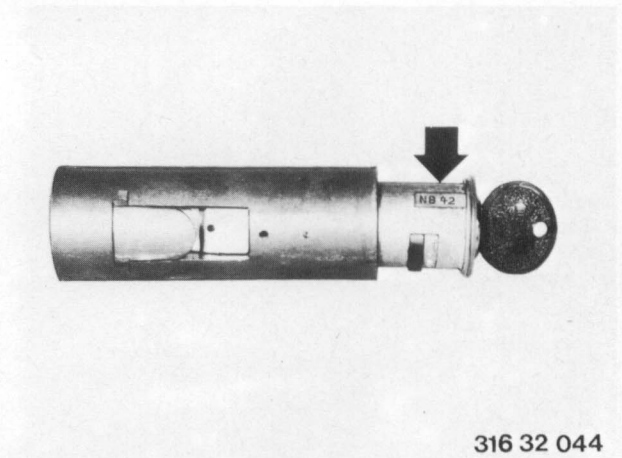

32 33 000 REMOVING AND INSTALLING STEERING WHEEL

Lift off padded crash pad.
Unscrew nut and remove steering wheel.

Installation Note! Install steering wheel that wheels point straight ahead.
Replace self-locking nut.¹⁾
Tighten to specified torque¹⁾.

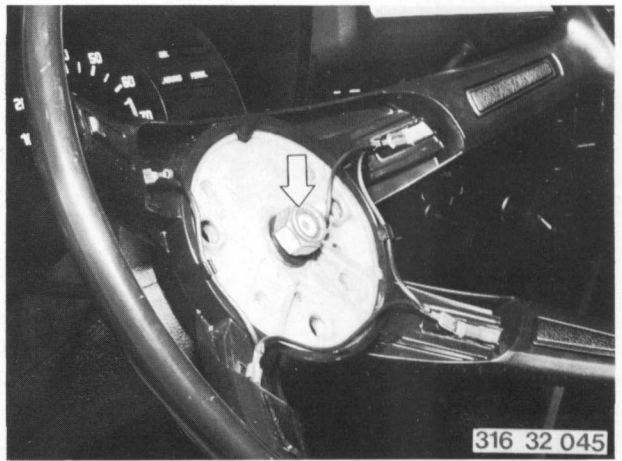

32 33 041 REPLACING STEERING WHEEL HORN BUTTON

Loosen screw from behind and remove horn button.

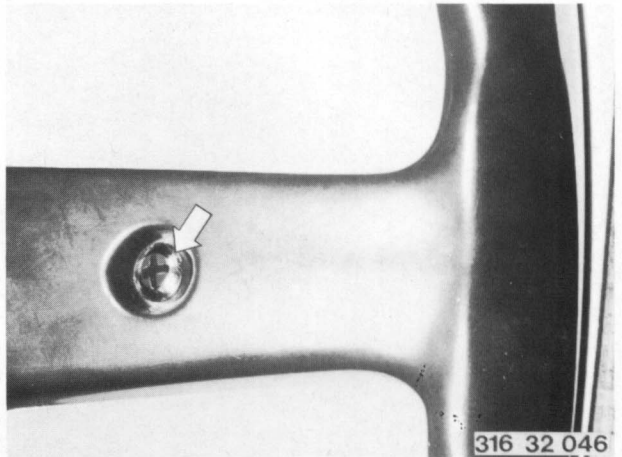

Installation Note! Note position of contact spring.
Contact pins face inward.

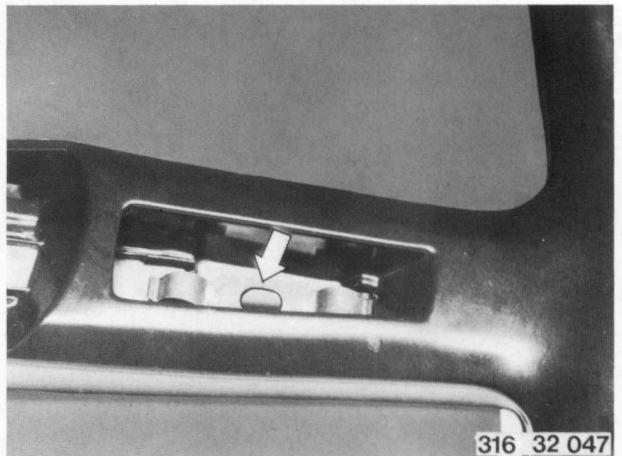

32 33 551 REPLACING CARBON BRUSH HORN CONTACT
- Steering Wheel Removed -

Disconnect plugs.

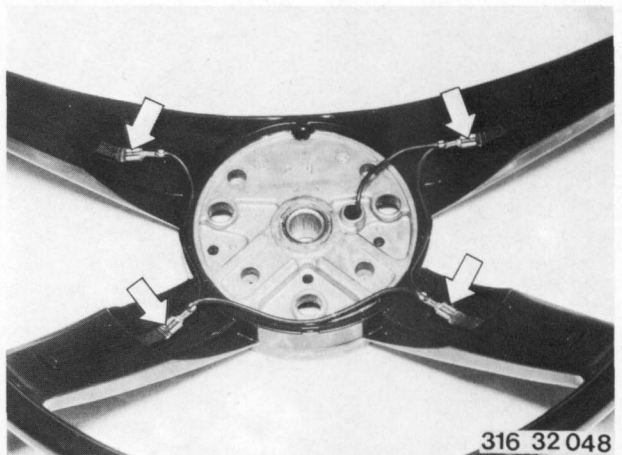

1) See Specifications

Loosen screws and remove horn contact.

